



LIFTING CHARTS - Boom Trucks

MANITOWOC MODEL 2892C - 28 TON CAPACITY

boom/jib range diagram

2892C-LMI Range Diagram

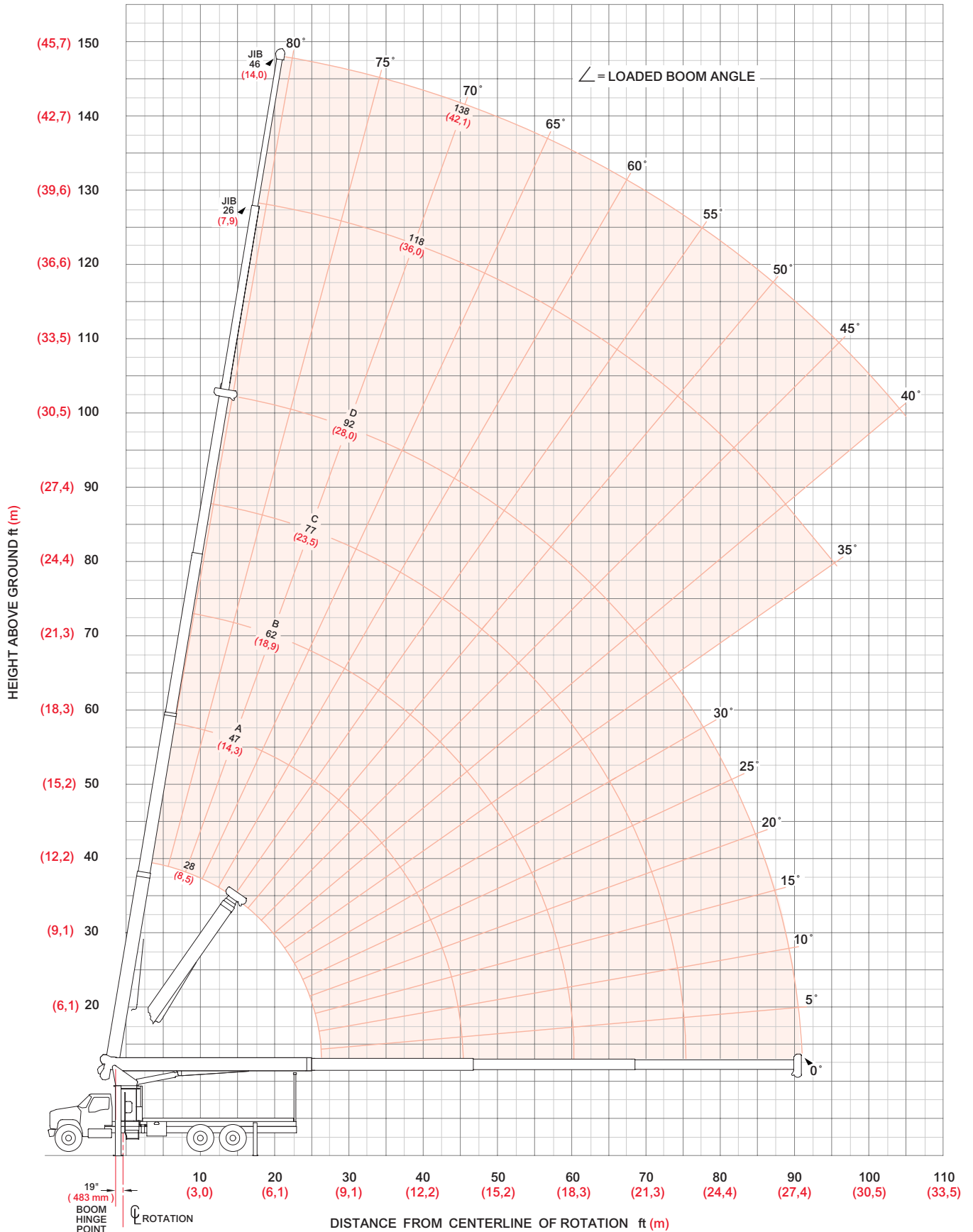

boom/jib load charts

2892C-LMI Load Ratings

2892C-LMI Jib Load Ratings

Boom/Jib ft (m)	A					B					C					D					Fixed Jib		Telescopic Jib			Boom/Jib ft (m)
	28 (8,5)	47 (14,3)	62 (18,9)	77 (23,5)	92 (28,0)	26 (7,9)	26 (7,9)	46 (14,0)	26 (7,9)	46 (14,0)	26 (7,9)	46 (14,0)	26 (7,9)	46 (14,0)	26 (7,9)	46 (14,0)	26 (7,9)	46 (14,0)	26 (7,9)	46 (14,0)	26 (7,9)	46 (14,0)				
Operating Radius ft (m)	∠	lb (kg)	∠	lb (kg)	∠	lb (kg)	∠	lb (kg)	∠	lb (kg)	∠	lb (kg)	∠	lb (kg)	∠	lb (kg)	∠	lb (kg)	∠	lb (kg)	∠	lb (kg)	∠	lb (kg)		
5	79°	56,000 (25 401)																							5 (1,5)	
8	72°	41,560 (18 851)																								8 (2,4)
10	68°	35,030 (15 889)	78°	20,500 (9 299)																						10 (3,1)
12	63°	30,330 (13 757)	75°	20,500 (9 299)	79°	20,500 (9 299)																				12 (3,7)
15	56°	25,230 (11 444)	71°	20,500 (9 299)	77°	20,500 (9 299)	80°	15,900 (7 212)																		15 (4,6)
20	42°	19,300 (8 754)	65°	17,780 (8 065)	72°	16,780 (7 611)	76°	13,540 (6 142)	79°	10,200 (4 627)																20 (6,1)
25	21°	13,760 (6 241)	58°	14,460 (6 559)	67°	13,610 (6 173)	73°	11,710 (5 312)	76°	9,290 (4 214)	79°	5,600 (2 540)	79°	5,400 (2 449)												25 (7,6)
30			50°	11,810 (5 357)	62°	11,390 (5 166)	69°	10,160 (4 608)	73°	8,330 (3 778)	77°	5,300 (2 404)	77°	5,100 (2 313)	79°	3,400 (1 542)										30 (9,1)
35			41°	8,800 (3 992)	56°	8,960 (4 064)	64°	8,830 (4 005)	70°	7,320 (3 320)	75°	4,960 (2 250)	75°	4,700 (2 132)	77°	3,300 (1 497)										35 (10,7)
40			30°	6,800 (3 084)	50°	6,950 (3 152)	60°	7,040 (3 193)	66°	6,460 (2 930)	72°	4,490 (2 037)	72°	4,230 (1 919)	76°	3,200 (1 451)										40 (12,2)
45			10°	5,350 (2 427)	43°	5,530 (2 508)	55°	5,610 (2 545)	63°	5,660 (2 567)	70°	4,080 (1 851)	70°	3,820 (1 733)	74°	3,040 (1 379)										45 (13,7)
50					36°	4,460 (2 023)	51°	4,540 (2 059)	59°	4,590 (2 082)	67°	3,710 (1 683)	67°	3,440 (1 560)	72°	2,800 (1 270)										50 (15,2)
55					26°	3,620 (1 642)	45°	3,710 (1 683)	55°	3,760 (1 706)	65°	3,380 (1 533)	65°	3,100 (1 406)	69°	2,630 (1 193)										55 (16,8)
60					9°	2,940 (1 334)	39°	3,050 (1 383)	51°	3,100 (1 406)	62°	3,080 (1 397)	62°	2,810 (1 275)	67°	2,480 (1 125)										60 (18,3)
65							33°	2,500 (1 134)	47°	2,550 (1 157)	59°	2,690 (1 229)	59°	2,400 (1 089)	65°	2,310 (1 048)										65 (19,8)
70							24°	2,050 (930)	42°	2,100 (953)	56°	2,230 (1 012)	56°	1,940 (880)	63°	2,110 (957)										70 (21,3)
75							8°	1,650 (748)	36°	1,720 (780)	53°	1,850 (839)	53°	1,560 (708)	60°	1,940 (880)										75 (22,9)
80									30°	1,390 (630)	50°	1,510 (685)	50°	1,220 (553)	58°	1,680 (762)										80 (24,4)
85									22°	1,100 (499)	46°	1,230 (558)	46°	940 (426)	55°	1,390 (630)										85 (25,9)
90									8°	840 (381)	42°	980 (445)	42°	680 (308)	52°	1,140 (517)										90 (27,4)
95											38°	750 (340)	38°	460 (209)	49°	910 (413)										95 (29,0)
100														46°	710 (322)											100 (30,5)
105														43°	530 (240)											105 (32,0)
Deduction*		460 (209)	270 (122)	210 (95)	170 (77)	140 (64)																				
Deduction**		690 (313)	410 (186)	310 (141)	250 (113)	210 (95)																				

*for stowed fixed jib

**for stowed telescopic jib

boom/jib range diagram

2892C-HYCAS Range Diagram

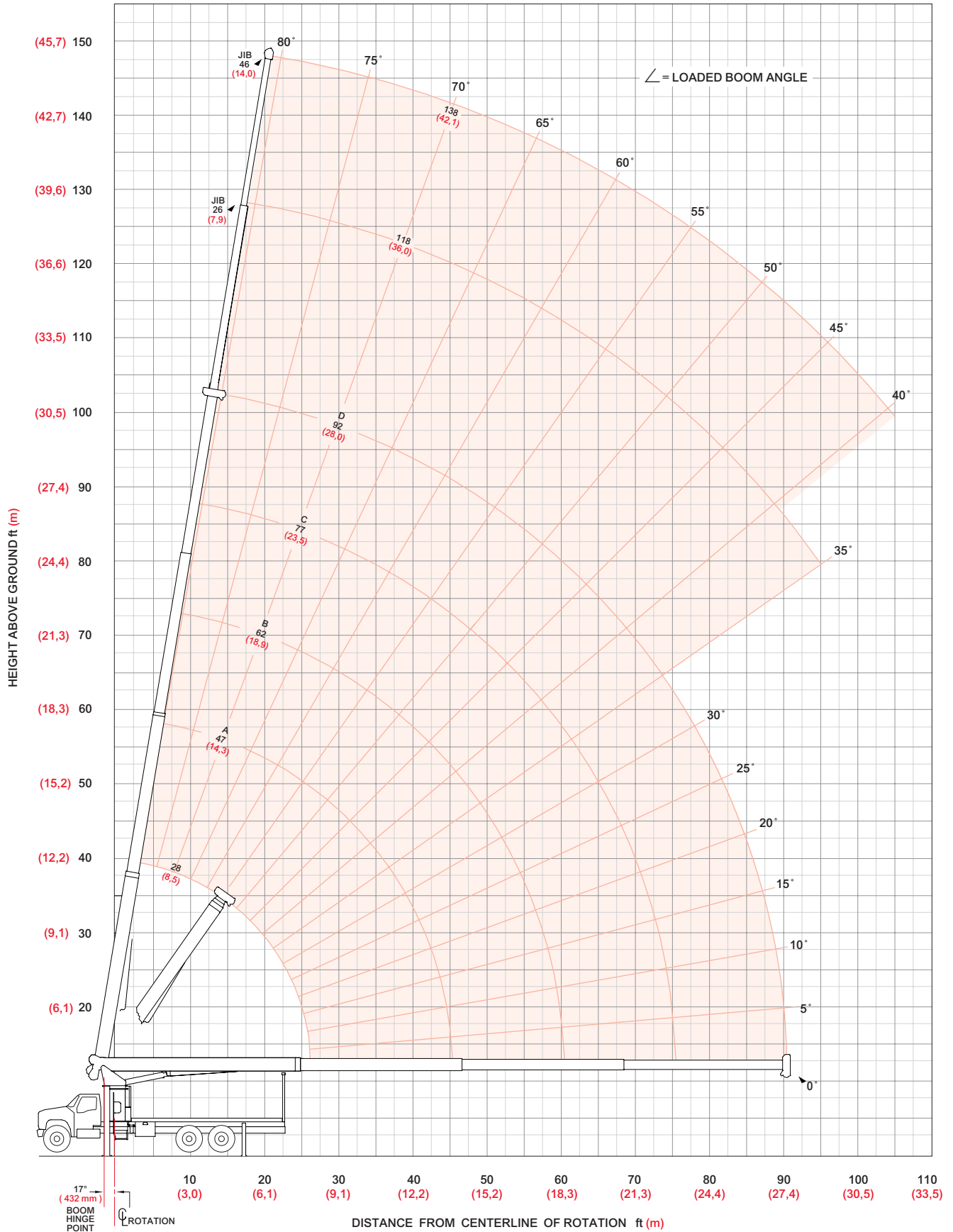

load chart data

Deductions

Auxiliary Block	50 lb (23 kg)
Auxiliary Sheave	50 lb (23 kg)
Overhaul Ball	See manufacturer's nameplate
Load Block	See manufacturer's nameplate
Hose Reel	140 lb (64 kg)
Swing-Around Jib	See load rating chart

Area of Operation

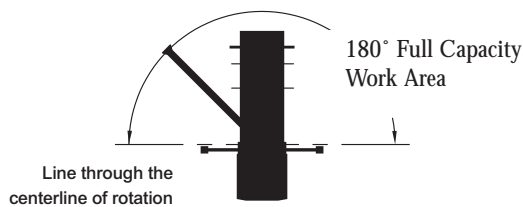

Allowable Line Pull

1 Part Line	2 Part Line	3 Part Line	4 Part Line	5 Part Line	6 Part Line	7 Part Line
7,400 lb (3 357 kg)	14,800 lb (6 713 kg)	22,200 lb (10 070 kg)	29,600 lb (13 426 kg)	37,000 lb (16 783 kg)	44,400 lb (20 140 kg)	51,800 lb (23 496 kg)
8,500 lb (3 856 kg)	17,000 lb (7 711 kg)	25,500 lb (11 567 kg)	34,000 lb (15 422 kg)	42,500 lb (19 278 kg)	51,000 lb (23 133 kg)	56,000 lb (25 401 kg)

9/16" 6 x 25 IWRC (3.5:1 SF) – 29,750 lb Min Breaking Strength

9/16" Rotation Resistant (5.0:1 SF) – 37,000 lb Min Breaking Strength

Warning

Anti-two-block system must be in good operating condition before operating crane. Refer to the owner's manual. Keep at least three wraps of load line on the drum at all times.

specifications

Upperworks



Boom

Boom – Inverted T-cross section, 4-section telescoping type, extended and retracted proportionally by double-acting hydraulic cylinder and cable-crowd system. Easily replaceable and adjustable high-density nylon slide pads. **2892C-LMI & HYCAS** – 4-section 28' (8,5 m) to 92' (28,0 m). Maximum main boom tip height 103' (31,4 m). 2-section, 26' (7,9 m) to 46' (14,0 m) jib. Maximum tip height 149' 1" (45,4 m).

Boom Points – Three high-density nylon sheaves mounted on heavy-duty roller bearings. Two removable pin-type rope guards. Quick-reeve boom point.

Boom Elevation – Double-acting hydraulic cylinder. Working range from 9° below horizontal to 80.6° above.



Hoist

Hoist – Maximum theoretical line speed 247 fpm (75,3 mpm). Maximum theoretical bottom-layer line pull 12,000 lbs (5 443 kg). Two-speed planetary reducer. Spring-applied, pressure-released internal brake. Wet multi-disc internal brake is spring-applied, pressure-released.

Wire Rope – 300' (91,4 m) of 9/16" (14,3 mm) diameter 6 x 25 EIPS IWRC.



Swing System

Externally mounted, double-reduction planetary driven by hydraulic motor. Maximum theoretical swing speed 1.5 rpm. Spring-applied, pressure-released parking brake. Ball-bearing swing circle with external gear. 372° non-continuous rotation.



Outriggers

A-frame link type with double-acting hydraulic cylinders operated independently for precise leveling. Bubble level located near outrigger controls.



Mounting

Mounting – Pedestal and subframe are mounted to chassis by threaded rods and clamp plates. No welding to truck chassis is required.

Stabilizers – Underframe out-and-down type with double-acting hydraulic cylinders operated independently for precise leveling.

Subframe – Torsion resistant, rigid 4-plate design, and mounted under crane full length of truck frame.

Rear Underride Protection – Supplied on factory mounted cranes. Fabricated structure mounted under rear of bed. Complies with Bureau of Motor Carrier Safety Standard 393.86.

Boom Rest – Heavy-duty, removable.



Control System

Dual operator platforms are equipped with four single-lever crane controls arranged to ANSI B30.5 standards. Fully proportional control valves and system pressure gauge. Each station also includes outrigger and stabilizer controls, engine start/stop, foot throttle, signal horn, boom-angle indicator, bubble levels, load chart, range diagram and audio and/or visual indicators to warn operator of overload condition.



Hydraulics

Hydraulic System – A 3-section vane pump direct-mounted to power take-off on truck transmission provides 35 gpm (133 lpm) to the hoist, 8 gpm (30 lpm) to the swing circuit and 18 gpm (68 lpm) to other crane functions. 70-gallon (265-liter) baffled reservoir includes suction ball valve with strainer and 25-micron filter in the return line. Use of SAE O-ring and face seal O-ring hydraulic fittings throughout system.

Hydraulic Cylinders – All load-holding cylinders are equipped with integral holding valves.



Warning Systems

Anti-Two-Block System – Audible warning and shutoff functions prevent hook from contacting boom point.

Back-Up Alarm – Electronic audible motion alarm activated when truck transmission is in reverse gear.

Load Moment Indicator – Senses boom hoist cylinder pressure, boom length and boom angle. Audio-visual warning indicates overload conditions and overload shutoff feature prevents continuing overload. Operator can access all relative crane configuration and load conditions via display at the operator station.



General

Electrical – State-of-the-art, weather-resistant components throughout. Automotive style electrical system for easy installation. Designed to withstand high pressure washing and varying climates.

specifications

Design/Welding – Design conforms to ANSI B30.5. Welding conforms to AWS D1.1. Tested to SAE 1063 and SAE 765.

Manuals – Operator, service and parts manuals depict correct crane operation, maintenance procedures and parts listing.

Warranty – 12-month warranty covers parts and labor resulting from defects in material and workmanship.

Warning

1. The operator must read and understand the owner's manual before operating this crane.
2. Positioning or operation of crane beyond areas shown on this chart is not intended or approved except where specified in owner's manual.
3. Loaded boom angles at specified boom lengths give only an approximation of the operating radius. The boom angle before loading should be greater to account for deflections. Do not exceed the operating radius for rated loads.
4. The operating radius shown in the jib rating chart is for fully extended boom only. When boom is not fully extended, use only loaded boom angle to determine load rating of jib.
5. For boom angles shown on jib load rating chart, use rating of next lower boom angle.
6. For boom lengths not shown, use rating of next shorter or longer boom length, whichever is less. For radii not shown, use rating of next longer radius.
7. Crane load ratings on outriggers are based on freely suspended loads with the machine leveled and standing on a firm, uniform supporting surface. No attempt shall be made to move a load horizontally on the ground in any direction.
8. Practical working loads depend on supporting surface, wind, and other factors affecting stability such as hazardous surroundings, experience of personnel, and proper handling, all of which must be taken into account by the operator.
9. The maximum load which may be telescoped is limited by hydraulic pressure, boom angle, and boom lubrication. It is safe to attempt to telescope any load within the limits of the load rating chart.
10. Lifting off the main boom point while the swing-around jib is erected is not intended or approved.
11. All load ratings above the heavy line are based on machine structural competence and do not exceed 85% of

tipping. Load ratings below are stability limited and do not exceed 85% of tipping.

12. Do not operate a Manitowoc truck-mounted crane or accessories within 10' (3,05 m) of live power lines.

13. This capacity chart is for reference only and must not be used for specific serial number cranes.

Information

1. Deductions must be made from rated loads for stowed jib, optional attachments, hooks, and loadblocks (see deduction chart). Weights of slings and all other load-handling devices shall be considered a part of the load.
2. Crane load ratings with outriggers are based on outriggers and stabilizers extended and set with machine leveled.
3. Load ratings above the heavy line are structurally limited capacities. Load ratings below the heavy line are stability limited capacities and do not exceed 85% of tipping.

Definitions

1. Operating radius (r) is the horizontal distance from the axis of rotation to the center of the vertical hoist line or tackle with load applied (see below).

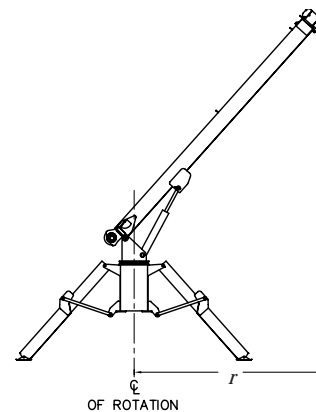

2. Loaded boom angle (\angle), as shown in the load chart columns headed by \angle , is the included angle between the horizontal and longitudinal axis of the boom base after lifting rated load at rated radius (see below).

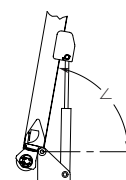

STERLING CRANE

outline dimensions

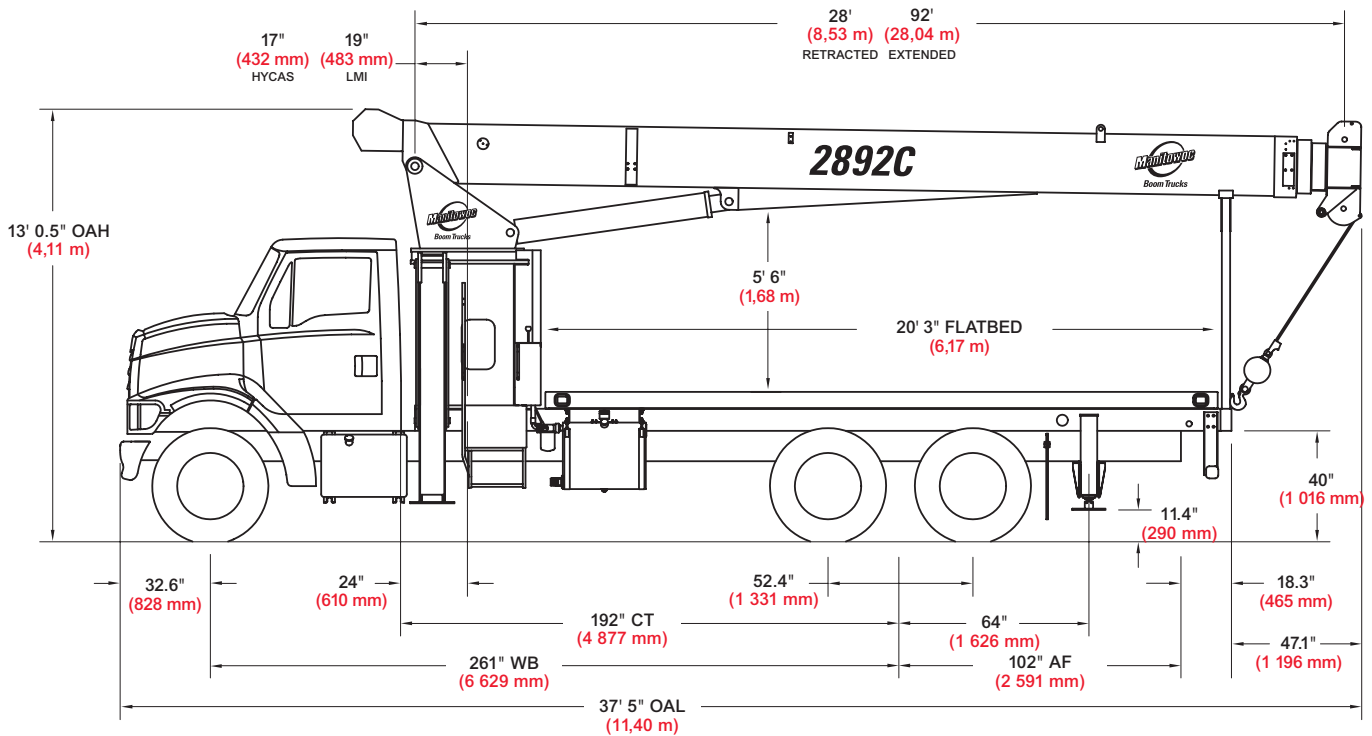

Chassis Data

Minimum Truck Requirements	2892C
Wheelbase (WB)	249" (6 325 mm)
Cab to Tandem (CT)	180" (4 527 mm)
After Frame (AF)	102" (2 591 mm)
Frame Section Modulus	20.0 in³ 110,000 psi (758 422 kPa)
Front Axle Gross Weight Rating	16,000 lb (7 257 kg)
Rear Axle Gross Weight Rating	34,000 lb (15 422 kg)
Minimum Truck Axle Weight - Front*	8,500 lb (3 856 kg)
Minimum Truck Axle Weight - Back*	8,150 lb (3 697 kg)
Nominal Frame Width	34" (864 mm)

Weights

	2892C
Total Crane - Standard	20,462 lb (9 282 kg)
Total Crane - Out-and-Down Outriggers (Out-and Down outrigger configuraton only avialable on LMI unit)	24,612 lb (11 164 kg)
20' (6,10 m) Flat Bed - Standard Outriggers	1,840 lb (835 kg)
22' (6,71 m) Flat Bed - Out-and-Down Outriggers	2,000 lb (907 kg)
26' (7,93 m) Fixed Length Jib	832 lb (377 kg)
26'-46' (7,93 m-14,02 m) Telescopic Jib	1,226 lb (556 kg)

*Minimum chassis weight is required to meet 85% stability requirements.

Chassis data is general - not for engineering. Some dimensions depend on truck selection.

- OAH Overall Height
- CT Cab to Tandem
- CA Cab to Axle
- WB Wheel Base
- OAL Overall Length
- BBC Bumper to Back of Cab
- AF Afterframe

STERLING CRANE

outline dimensions

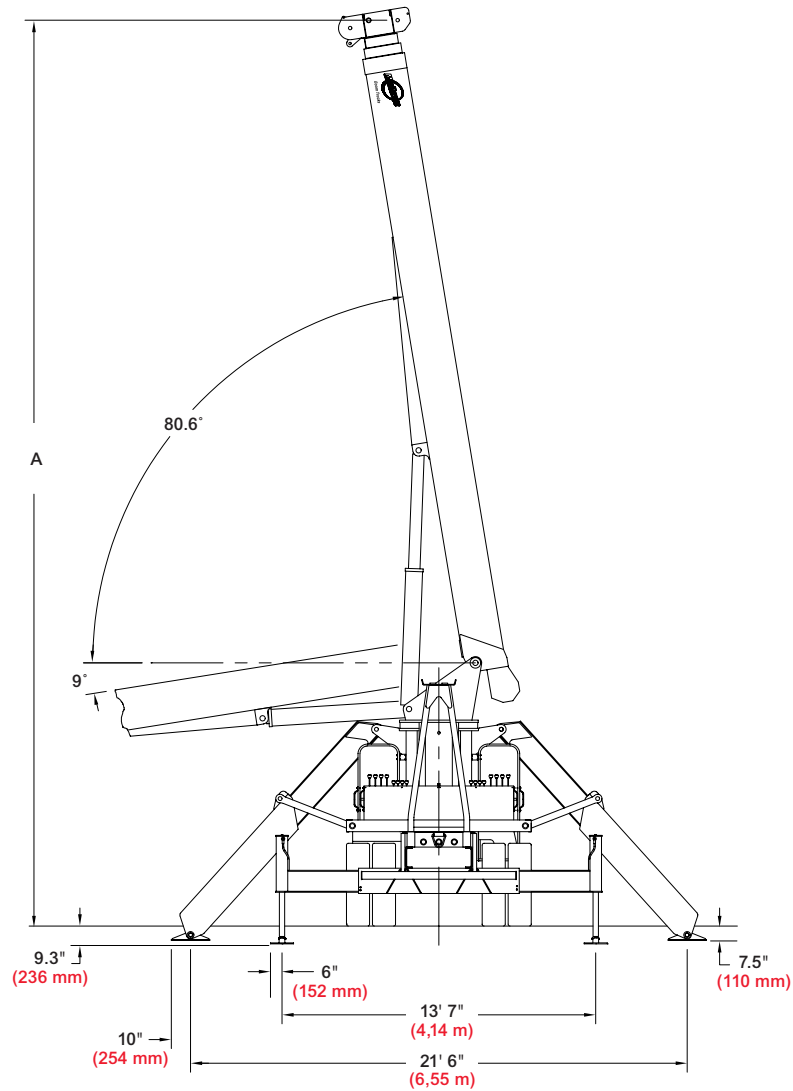

Maximum Tip Height (A)

Configuration	2892C Boom 92' (28,0 m)
Extended Boom	103' (31,4 m)
Fixed or Retracted Jib	129' 4" (39,4 m)
Extended Jib	149' (45,4 m)