

STERLING CRANE



LIFTING CHARTS - Carry Decks

BRODERSON MODEL IC-80-1F/2F/3F - 8.5 TON CAPACITY

IC-80-1F 8' 2" - 20' 2" BOOM

CAPACITIES APPLY TO OPERATION ON FIRM LEVEL SURFACE						
LOAD RADIUS FEET	MAIN BOOM OR EXTENSION CAPACITIES IN POUNDS					
	360 DEGREE ROTATION		OVER FRONT			
	ON RUBBER	ON OUTRIGGERS	ON RUBBER	ON RUBBER	ON OUTRIGGERS	
M	5	9600	17000	11700	17000	
A	6	7900	14500	10400	14500	
I	8	5750	10250	8400	10250	
N	10	4150	7700	6300	7700	
	12	3100	6550	4650	6550	
B	14	2425	5550	3650	5550	
O	16	1975	4650	3000	4650	
O	18	1625	3950	2500	4150	
M	20	1400	3550	2150	3800	
	22	1275	3000	1900	3000	
10'	24	1075	2750	1650	2800	
B	26	925	2450	1425	2600	
O	28	775	2150	1250	2400	
O	30	675	1950	1100	2250	
M	10 - FOOT BOOM EXTENSION - STRAIGHT OR OFFSET					
	BOOM EXT. ANGLE	MAIN BOOM ANGLE				
0°		30°	45°	60°	70°	
-0°		2250	2600	3200	5000	7000
-15°		---	2400	2700	3500	4200
-30°		---	2250	2500	3000	3300

* Use 0° for straight boom extension.

- Use 0°, 15° or 30° for offset boom extension. Boom extension loads must not exceed main boom capacity.

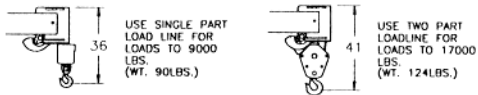

IC-80-2F 9' 6" - 24' 0" BOOM

CAPACITIES APPLY TO OPERATION ON FIRM LEVEL SURFACE						
LOAD RADIUS FEET	MAIN BOOM OR EXTENSION CAPACITIES IN POUNDS					
	360 DEGREE ROTATION		OVER FRONT			
	ON RUBBER	ON OUTRIGGERS	ON RUBBER	ON RUBBER	ON OUTRIGGERS	
M	5	9500	17000	11600	17000	
A	6	7800	14500	10200	14500	
I	8	5500	10250	8250	10250	
N	10	3900	7700	6200	7700	
	12	2900	6550	4550	6550	
B	14	2300	5550	3550	5550	
O	16	1850	4550	2850	4550	
O	18	1550	3950	2400	4050	
M	20	1300	3250	2050	3650	
	22	1100	2875	1750	3300	
	24	925	2475	1550	3100	
10'	26	850	2250	1350	2750	
B	28	700	2000	1175	2500	
O	30	600	1775	1025	2300	
O	32	500	1625	900	2100	
O	34	425	1400	800	1950	
M	10 - FOOT BOOM EXTENSION - STRAIGHT OR OFFSET					
	BOOM EXT. ANGLE	MAIN BOOM ANGLE				
0°		30°	45°	60°	70°	
-0°		2250	2600	3200	5000	7000
-15°		---	2400	2700	3500	4200
-30°		---	2250	2500	3000	3300

* Use 0° for straight boom extension.

- Use 0°, 15° or 30° for offset boom extension. Boom extension loads must not exceed main boom capacity.

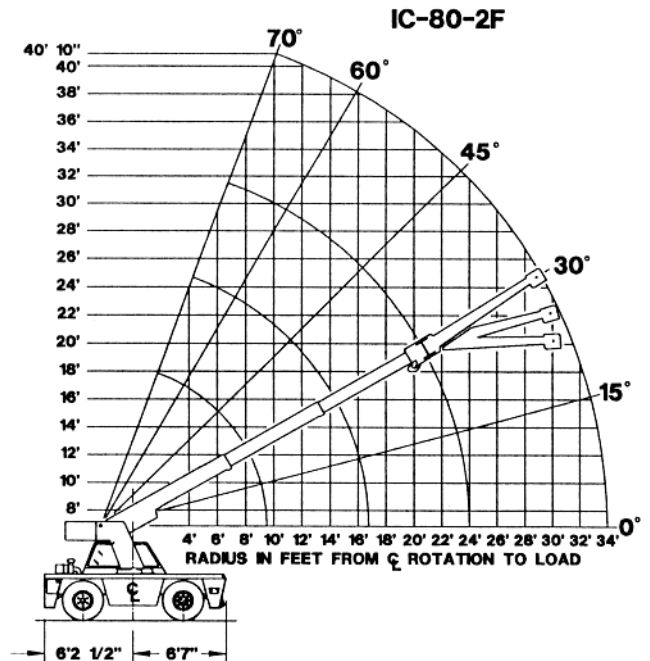
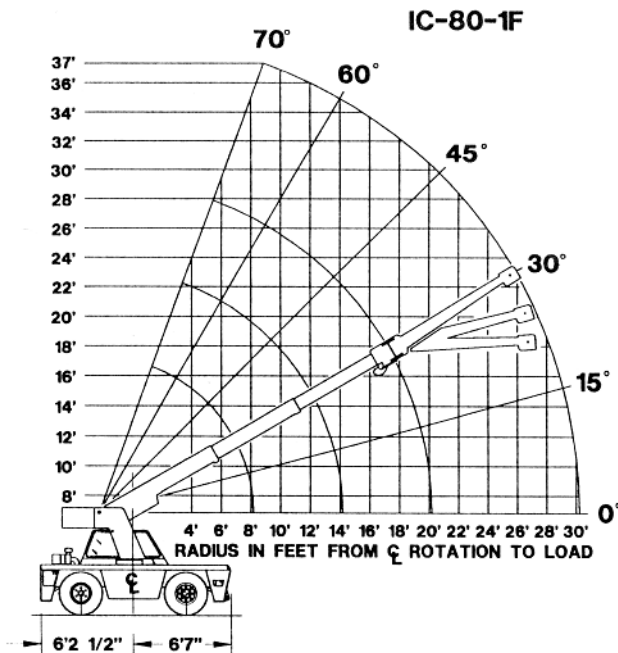
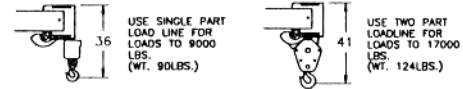

STERLING CRANE

IC-80-3F 11' 6" - 30' 0"

CAPACITIES APPLY TO OPERATION ON FIRM LEVEL SURFACE						
MAIN BOOM OR EXTENSION CAPACITIES IN POUNDS						
LOAD RADIUS FEET	360 DEGREE ROTATION OVER FRONT					
	ON RUBBER		ON OUTRIGGERS			
M A I N B O O M	5	9400	17000	11400	17000	
	6	7550	14000	10000	14000	
	8	5250	10000	8100	10000	
	10	3600	7700	6100	7700	
	12	2650	6100	4450	6100	
	14	2050	5200	3400	5200	
	16	1600	4400	2700	4400	
	18	1250	3650	2200	3900	
	20	1050	3050	1800	3400	
	22	850	2650	1550	3050	
	24	750	2300	1350	2800	
	26	650	2050	1150	2550	
10' B O O M E X T E N S I O N	28	550	1850	1000	2350	
	30	450	1650	900	2150	
	32	350	1550	750	1950	
	34	250	1400	650	1800	
	36	200	1250	550	1650	
	38	150	1100	450	1500	
	40	100	1000	400	1400	
	10 - FOOT BOOM EXTENSION - STRAIGHT OR OFFSET					
MAIN BOOM ANGLE						
	0°	30°	45°	60°	70°	
B	-0°	2250	2600	3200	5000	7000
X	-15°	---	2400	2700	3500	4200
T	-30°	---	2250	2500	3000	3300

* Use 0° for straight boom extension.

- Use 0°, 15° or 30° for offset boom extension. Boom extension loads must not exceed main boom capacity.

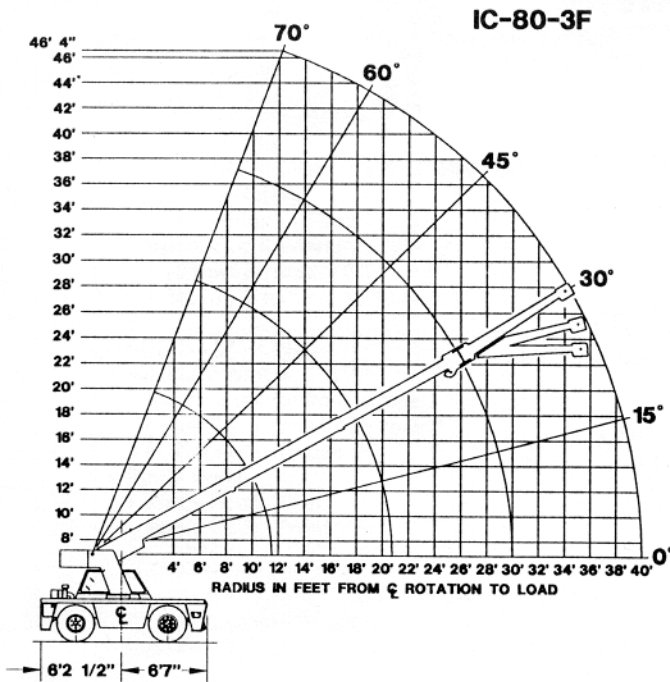
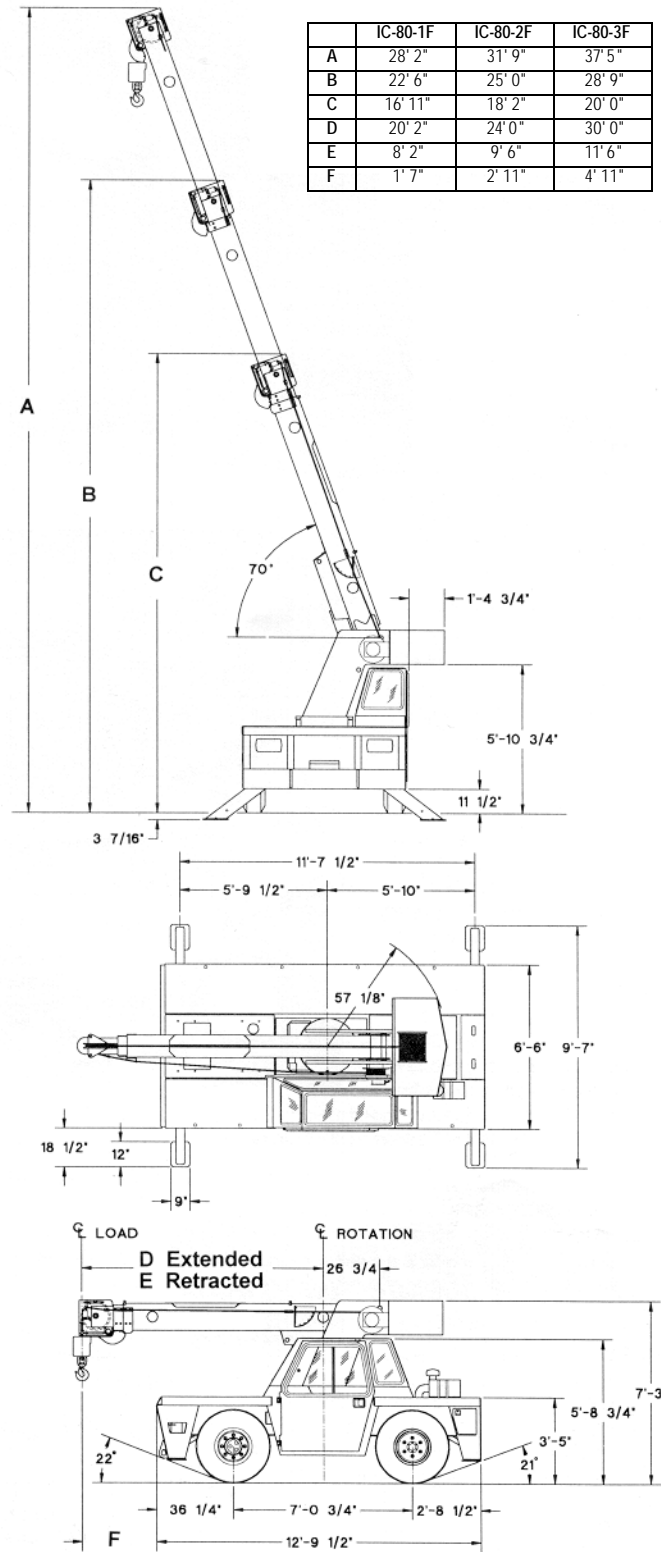
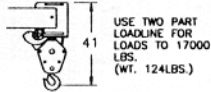
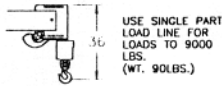

Boom Hoist

Turret mounted planetary gear hoist hydraulically powered with a bare drum line pull of 10,000 lbs. at a line speed of 110 FPM. Includes downhaul weight, swivel hook and sheave block for 2-part line and 125 ft. of 9/16" hoist rope.