



LIFTING CHARTS - Conventional Truck Cranes

GROVE MODEL HL150T - 150 TON CAPACITY

Superstructure specifications

Boom 68A	General purpose, optimized for straight boom or boom and fixed jib operations, consisting of basic 50 ft. (15.2m) boom (25 ft. [7.6m] base, 25 ft. [7.6m] point). Open throat point section is equipped with six sheaves mounted on heavy duty roller bearings, offset for improved throat clearance, 22 in. (559mm) pitch diameter. Boom extensions are 10 ft. (3m), 20 ft. (6.1m) and 40 ft. (12.2m) in length. Maximum boom length is 280 ft. (85.3m). Overall boom cross section dimensions are 68 in. (1727mm) deep by 76 in. (1930mm) wide. May be fitted with optional 32A fixed jib or 4 ft. (1.2m) auxiliary sheave point.	Load Moment & Anti-Two Block System	Standard load moment and anti-two block system with audio-visual warning and control lever lockout. These systems provide electronic display of boom angle, length, radius, tip height, relative load moment, maximum permissible load, load indication and warning of impending two-block condition.
Boom 76A	More versatile, larger and heavier than 68A boom, may be fitted with 32A fixed jib or 46A luffing jib assembly. 76A basic 50 ft. (15.2m) boom consists of two piece 25 ft. (7.6m) base and 25 ft. (7.6m) point section. Boom point section is equipped with six sheaves mounted on heavy duty roller bearings, offset for improved throat clearance, 22 in. (559mm) pitch diameter. Maximum boom length is 240 ft. (73.2m). Boom extensions are 10 ft. (3m), 20 ft. (6.1m) and 40 ft. (12.2m) in length. Overall boom cross section is 76 in. (1930mm) deep by 89 in. (2261mm) wide. Wind speed monitor with audible warning.	Cab	Full vision, steel fabricated with acoustical lining and tinted safety glass throughout. Sliding left side door, sliding right side window for ventilation. Hinged skylight with electric wiper. Full engine instrumentation with fuel gauge and audio/visual warning system for all important machine functions. Fabric seat with short stroke levers at arm rest positions. Seat tilts back 10 degrees for increased high boom angle visibility.
Mast Assembly	27 ft. (8.2m) Live Mast equipped with 23 in. (584mm) pitch diameter roller bearing sheaves. Can be used as auxiliary lifting boom with standard component handling equipment, for self erection of machine counterweights, boom componentry and outrigger assemblies.	Engine	Detroit Diesel 6V-92TA, V-6, 2 cycle, turbocharged and after cooled, 552 cu. in. (9.0 liter), 345 HP (257 kw) (Gross) @ 2100 RPM, 330 HP (246 kw) (SAE NET) @ 2100 RPM.
32A Fixed Jib	Maximum length is 90 ft. (27.4m) variable in 20 ft. (6.1m) increments to basic 30 ft. (9.1m) length consisting of 15 ft. (4.6m) base and 15 ft. (4.6m) point section. This jib may be mounted on the 68A boom and the 76A boom utilizing an adaptor assembly. Jib overall cross section is 32 in. (813mm) deep by 38 in. (965mm) wide.	Optional Engine	Cummins LTA10-C325 six cylinder turbocharged and after cooled diesel, 611 cu. in. (10 liter), 325 HP (242 kw) (Gross) @ 2100 RPM. Maximum torque 975 ft. lbs. (1450 kg/m) @ 1300 RPM.
46A Luffing Jib (For 76A Boom Only)	Four piece 80 ft. (24.4m) basic jib consisting of 20 ft. (6.1m) base, two 20 ft. (6.1m) jib extensions and 20 ft. (6.1m) tip section. Maximum jib length is 160 ft. (48.8m). Cross section dimensions are 46 in. (1168mm) deep and 59 in. (1499mm) wide. Includes electronic wind speed indication.	Fuel Tank Capacity	85 gallons (322 liter)
Boom Hoist System	Hydraulic driven dual drum with standard ratchets and pawls, enclosed multi-disc wet brake spring set, hydraulically released. Drums utilize 1 in. (25.4mm) wire rope and have a pitch diameter of 23 in. (584mm). 10 part reeving standard, optional 12 part reeving necessary for 76A boom and 46A luffing jib operation. Gantry and mast utilize 23 in. (584mm) pitch diameter sheaves with anti-friction bearings. Automatic boom hoist kickout at 81 degrees.	Swing	Ball bearing swing circle with 360° continuous rotation. Planetary glide swing with static holding multi-disc wet brake actuated with brake hold button on control lever and/or switch operated parking brake. Rotation is stopped by back plugging swing controller. Plunger type, 2 position, mechanical house lock. Maximum speed: 2.5 rpm.
		Counterweights	Two piece totaling 59,000 lbs. (26762 kg). Counterweight "A" equals 17,500 lbs. (7938 kg), and counterweight "C" equals 41,500 lbs. (18825 kg). Counterweights hook on for quick and easy handling.

STERLING CRANE

Superstructure specifications (continued)

HYDRAULIC SYSTEM

Pumps	Four main pumps, one for each function: front hoist, rear hoist, boom hoist, and swing. All main pumps are variable displacement axial piston type. Pumps driven by common gearbox with disconnect clutch.
Controls	Short stroke low pressure hydraulic controllers stroke pumps to determine direction and speed of each function.
Filtration	100% 7 micron filtration of charge and control pressure circuits.
Reservoir	75 gallon (284 liter) capacity with internal diffusers and magnets. Electric fill pump with spin-on filter cartridge provided.
Oil Cooler	Remote mounted with thermostatically controlled hydraulic motor powered fan. High oil temperature warning light provided in operator's cab.

HOIST SPECIFICATIONS

	Power up and down 2 speed operation standard with ratchet and pawl. Semi-automatic hoist brake feature with free fall to 10,000 lbs. (4535 kg) capacity on foot operated caliper brake pedals. Electronic hoist drum rotation indicators.
MAKE/MODEL	Front and Rear Hoists Grove HO60-29
Drum Dimensions	21 in. (533mm) diameter 29 in. (737mm) length 35 in. (889mm) flange diameter

Line Pull and Line Speed Combinations (4th Layer)

Based on Maximum Permissible Single Line Pull of 29,500 lbs. (13,381 kg) for 1 in. (25.4mm) diameter wire rope - main hoist drums only.

Single Line Pull		Low Speed Mode	
Pounds	Kilograms	FPM	Speed m/min.
29,500	13381	185	56.4
25,000	11340	220	67.1
20,000	9072	240	73.1
15,000	6804	250	76.2
10,000	4536	255	77.7
5,000	2268	260	79.2
1,000	454	260	79.2

Single Line Pull		High Speed Mode	
Pounds	Kilograms	FPM	Speed m/min.
15,000	6804	320	97.5
12,500	5670	390	118.9
10,000	4536	455	138.7
7,500	3402	485	147.8
5,000	2268	500	152.4
2,500	1134	515	157.0
1,000	454	520	158.5

Maximum Permissible Line Pull Based On

1 in. dia. (25.4mm) 6 x 25 w/3.5:1 F.O.S.
29,500 lbs. (13381 kg)
1 in. dia. (25.4mm) 18 x 19 w/5:1 F.O.S.
22,760 lbs. (10324 kg)
25 mm (0.984 in.) 34 x 7 w/5:1 F.O.S.
27,170 lbs. (12325 kg)

Rope Stowage Usable - 1,190 ft. (363m)
Stowable - 1,440 ft. (439m)

Third Hoist Luffing jib hoist, power up and down, 2 speed operation standard with ratchet and pawl, enclosed multi-disc wet brake, spring set hydraulically released. Drum utilizes 3/4 in. (19mm) dia. wire rope. Stowable capacity - 790 ft. (241m). Recommended length - 680 ft. (207m), required for luffing jib.

*Denotes optional equipment.

STERLING CRANE

Carrier specifications

Frame	High strength alloy steel, triple box rear section and channel front section, all welded, with machined surface for turntable bearing.	Transmission	Fuller gearbox with 9 speeds forward and 2 reverse, with 2 speed auxiliary.
Bumper	Counterweight "L", one piece - 12,000 lbs. (5443 kg).	Axles	Axles 1 & 2, steering, tubular steel, 115.4 in. (2931mm) track.
Counterweight	Pin connected to front of carrier, power removed and installed with mast component handling equipment. (Refer to capacity chart for counterweight requirements).		Axles 3 & 4, single reduction drive, 100 in. (2540mm) track.
HYDRAULIC SYSTEM			
Pump	Single vane type pump driven by carrier engine provides flow to the steer and outrigger circuits.	Suspension	Front axles (1 & 2) spring mounted tandem. *Optional hydraulic spring suspension lockout system. Rear axles (3 & 4) solid mount tandem with equalizing beam and solid steel saddles.
Filter	Return line type, full flow with bypass protection and filter bypass indicator, replaceable 25 micron cartridge, remote mounted.	Tires	14.00x24-20PR highway tread, tube type-front and rear. *14.00R24-20PR radial, tube type - front and rear. *16.00R21-22PR radial, tubeless type - front only.
Reservoir	35 gallon (132.5 liters) capacity with spin on breather, external sight gauges, clean out access, internal diffusers and magnet.	Brakes	Full air on all wheels. Air dryer provided to preclude moisture accumulation. Spring set, air released emergency/parking brake on both rear axles.
Outrigger System	Hydraulic single stage double box telescopic beam and jack outriggers with integral holding valves. Removable, pinned to carrier frame. Mid frame box equipped with tilting jack and suspended on integral rail, allowing box to roll out from under frame. Standard 5th vertical jack mounted to the front center section to permit 360° lifting capacities. *Optional mechanical outrigger spin locks, for main jacks only. *Optional rear stabilizing jacks, for erecting certain boom lengths (Refer to capacity charts for rear stabilizer requirements). All steel fabricated quick release type outrigger floats 30.5" (775mm) diameter for main jacks, 24" (610mm) diameter for front jack and rear stabilizers.	Lights	Full lighting including head, tail, braking, reversing, directional and hazard warning lights.
Outrigger Controls	Located on both sides of carrier. Controls provided for beam and jack extension/retraction as well as engine speed.	Cab	One man design, all steel fabricated with acoustical lining and tinted safety glass throughout. Deluxe fabric covered fully adjustable seat. Complete driving controls with full engine instrumentation, low air A/V warning system, air circulating fan, heater, defroster, windshield washer/wiper, sliding right side window, roll up left side window, fire extinguisher and seat belt.
Engine	Detroit Diesel 6V-92TA, V6, 2 cycle, turbocharged and after cooled, 552 cu. in. (9.0 liter), 335 HP (250 kw) (Gross) @ 2100 RPM, 304 HP (227 kw) (SAE NET) @ 2100 RPM.		
*Optional Engine	Cummins N14-460E, six cylinder turbocharged and after cooled diesel. 855 cu. in. (14 liter), 460 HP (343 kw) @ 1600 RPM, 350 HP (261 kw) @ 2100 RPM Maximum torque 1550 ft. lbs. (2102 kg/m) @ 1200 RPM with engine brake and audio-visual engine distress system.		
Fuel Tank Capacity	100 gallons (379 liters).		
Electrical	Four 12 volt - maintenance free batteries, 750 CCA @ 0 degrees F. 24 volt starting, 90 amp alternator.		
Drive	8 x 4		
Steering	Front axle steering, gear type with hydraulic assist.		

STERLING CRANE

Carrier specifications (continued)

SPEED AND GRADEABILITY 90,000 LBS. (40824 kg) GVW

SPEED RANGES AT MAXIMUM GOVERNED RPM		% GRADEABILITY AT MAXIMUM TORQUE	
AUXILIARY LOW	AUXILIARY DIRECT	AUXILIARY LOW	AUXILIARY DIRECT
1.8 to 23.2 mph (2.9 to 37.3 kph)	3.7 to 48 mph (6.0 to 77.2 kph)	72.3 to 4.3%	34.7 to 1.3%

NOTE: Performance data based on 90,000 lbs. (40824 kg) GVW, standard engine, transmission, axles and 14:00x24-20PR tires. Performance data may vary \pm 10% due to variations in engine performance and vehicle weights.

Miscellaneous Standard Equipment	Tire inflation kit, mud flaps, pressure protected air system, outrigger controls (on both sides of carrier) outrigger pad storage, cold start aid (less canister), engine distress A/V warning system, air cleaner service indicator, air dryer, air horn, front tow loops, west coast mirrors (both sides), pump disconnect, hoist drum rotation indicators and back up alarm.
---	---

Miscellaneous Optional Equipment	Jacobs engine brake, cold weather package, front suspension lockout, hydraulic powered foot pins, auxiliary rear stabilizers, mechanical outrigger spinlocks, rigging box, 360° swing lock, rotating beacon, boom mounted floodlights, extendible work platforms (both sides of superstructure), component handling assembly and third hoist.
---	---

*Denotes optional equipment.

AXLE LOADINGS AND WEIGHTS - (APPROXIMATE)

Quick Reference Combinations	(Boom Foot Pins to Rear)		GVW	(Boom Foot Pins to Front)	
	Front Axles	Rear Axles		Front Axles	Rear Axles
A. Std. Machine with Boom Hoist Rope - No Mast. Bridle is at Boom Foot. No Outrigger Boxes, Counterweights, Boom Stops or Boom, Full Fuel Tanks	41,615 lbs. (18876 kg)	41,417 lbs. (18787 kg)	83,032 lbs. (37663 kg)	19,887 lbs. (9021 kg)	63,145 lbs. (28642 kg)
B. ADD: Mast and 1,000 ft. (305m) of Hoist 1 in. rope to Front and Rear Hoist Drums	39,131 lbs. (17750 kg)	50,233 lbs. (22786 kg)	89,364 lbs. (40536 kg)	23,156 lbs. (10504 kg)	66,208 lbs. (30032 kg)
C. ADD: 25 ft. (7.6m) 68A Boom Base Section with Component Handling Option	37,824 lbs. (17157 kg)	56,093 lbs. (25444 kg)	93,917 lbs. (42600 kg)	26,306 lbs. (11932 kg)	67,611 lbs. (30668 kg)
D. ADD: 25 ft. (7.6m) 76A Boom Base Section with Component Handling Option in lieu of Item C	34,551 lbs. (15672 kg)	62,314 lbs. (28265 kg)	96,865 lbs. (43937 kg)	30,765 lbs. (13955 kg)	66,100 lbs. (29982 kg)
E. Complete Std. Crane with 50 ft. (15.2m) 68A Basic Boom	107,090 lbs. (48576 kg)	76,470 lbs. (34687 kg)	183,560 lbs. (83263 kg)	26,725 lbs. (12122 kg)	156,835 lbs. (71140 kg)
F. Complete Std. Crane with 50 ft. (15.2m) 76A Basic Boom	98,943 lbs. (44880 kg)	92,247 lbs. (41842 kg)	19,190 lbs. (86722 kg)	36,621 lbs. (16611 kg)	154,569 lbs. (70111 kg)

STERLING CRANE

Axle Loadings and Weights (continued)

WEIGHT ADJUSTMENTS FOR COMPLETE STANDARD CRANE WITH 50 FT. (15.2m) 68A OR 76A BASIC BOOM - ITEMS E OR F

Quick Reference Combinations	(Boom Foot Pins to Rear)			(Boom Foot Pins to Front)	
	Front Axles	Rear Axles	GVW	Front Axles	Rear Axles
REMOVE:					
Counterweight "A"	-15,937 lbs. (-7229 kg)	-1,563 lbs. (-709 kg)	-17,500 lbs. (-7938 kg)	8,878 lbs. (4027 kg)	-26,378 lbs. (-11965 kg)
Counterweight "C"	-41,151 lbs. (-18666 kg)	-349 lbs. (-158 kg)	-41,500 lbs. (-18824 kg)	24,412 lbs. (11073 kg)	-65,912 lbs. (-29898 kg)
Bumper Counterweight "L"	-18,841 lbs. (-8546 kg)	6,841 lbs. (3103 kg)	-12,000 lbs. (-5443 kg)	-18,841 lbs. (-8546 kg)	6,841 lbs. (3103 kg)
Boom Point Section (68A)	8,974 lbs. (4070 kg)	-13,100 lbs. (-5942 kg)	-4,126 lbs. (-1872 kg)	-10,638 lbs. (-4825 kg)	6,512 lbs. (2953 kg)
Boom Base Section (68A)	2,151 lbs. (976 kg)	-5,335 lbs. (-2420 kg)	-3,184 lbs. (-1444 kg)	-3,435 lbs. (-1558 kg)	251 lbs. (114 kg)
Boom Point Section (76A)	14,586 lbs. (6616 kg)	-21,206 lbs. (-9619 kg)	-6,620 lbs. (-3002 kg)	-17,256 lbs. (-7827 kg)	10,636 lbs. (4825 kg)
Boom Base Section (76A) (Include 10' Ext.)	3,750 lbs. (1700 kg)	-9,880 lbs. (-4481 kg)	-6,130 lbs. (-2780 kg)	-6,225 lbs. (-2823 kg)	95 lbs. (43 kg)
Front Outrigger Box Assembly with Pads	-5,620 lbs. (-2549 kg)	-2,585 lbs. (-1173 kg)	-8,205 lbs. (-3722 kg)	-5,620 lbs. (-2549 kg)	-2,585 lbs. (-1173 kg)
Rear Outrigger Box Assembly with Pads	2,571 lbs. (1166 kg)	-11,071 lbs. (-5022 kg)	-8,500 lbs. (-3856 kg)	2,571 lbs. (1166 kg)	-11,071 lbs. (-5022 kg)
Mast	2,345 lbs. (1064 kg)	-5,128 lbs. (-2326 kg)	-2,783 lbs. (-1262 kg)	-3,467 lbs. (-1573 kg)	684 lbs. (310 kg)
Bridle	1,639 lbs. (743 kg)	-2,982 lbs. (-1353 kg)	-1,343 lbs. (-609 kg)	-2,181 lbs. (-989 kg)	838 lbs. (380 kg)
Boom Stops	-223 lbs. (-101 kg)	-509 lbs. (-231 kg)	-732 lbs. (-332 kg)	-73 lbs. (-33 kg)	-659 lbs. (-299 kg)
Outrigger Pads (5)	-86 lbs. (-39 kg)	-353 lbs. (-160 kg)	-439 lbs. (-199 kg)	-86 lbs. (-39 kg)	-353 lbs. (-160 kg)
Front Hoist Assembly	-665 lbs. (-302 kg)	-3,465 lbs. (-1572 kg)	-4,130 lbs. (-1873 kg)	-665 lbs. (-302 kg)	-3,465 lbs. (-1572 kg)
Rear Hoist Assembly	-1,498 lbs. (-679 kg)	-2,673 lbs. (-1212 kg)	-4,171 lbs. (-1892 kg)	-184 lbs. (-83 kg)	-3,987 lbs. (-1809 kg)
ADD:					
Cummins Engines	1,440 lbs. (653 kg)	-290 lbs. (-131 kg)	1,150 lbs. (522 kg)	1,440 lbs. (653 kg)	-290 lbs. (-131 kg)
Front Hoist Rope (1,000 ft.)	373 lbs. (169 kg)	1,477 lbs. (670 kg)	1,850 lbs. (839 kg)	373 lbs. (169 kg)	1,477 lbs. (670 kg)
Rear Hoist Rope (1,000-ft.)	643 lbs. (292 kg)	1,207 lbs. (548 kg)	1,850 lbs. (839 kg)	103 lbs. (47 kg)	1,747 lbs. (792 kg)
Third Hoist Assembly (76A)	220 lbs. (100 kg)	2,158 lbs. (979 kg)	2,378 lbs. (1079 kg)	1,179 lbs. (535 kg)	1,199 lbs. (544 kg)
Third Hoist Rope (76A)	65 lbs. (29 kg)	642 lbs. (291 kg)	707 lbs. (321 kg)	351 lbs. (159 kg)	356 lbs. (161 kg)
Boom Base Component Handling Equipment (68A)	-737 lbs. (-334 kg)	1,184 lbs. (537 kg)	447 lbs. (203 kg)	917 lbs. (416 kg)	-470 lbs. (-213 kg)
Boom Base Component Handling Equipment (76A)	-1,053 lbs. (-477 kg)	1,692 lbs. (767 kg)	639 lbs. (290 kg)	1,311 lbs. (595 kg)	-672 lbs. (-305 kg)
Auxiliary Stabilizers	1,490 lbs. (676 kg)	-470 lbs. (-213 kg)	1,020 lbs. (463 kg)	1,490 lbs. (676 kg)	-470 lbs. (-213 kg)
Outrigger Spinlocks	67 lbs. (30 kg)	293 lbs. (133 kg)	360 lbs. (163 kg)	67 lbs. (30 kg)	293 lbs. (133 kg)
Hydraulic Spring Suspension Lockouts	199 lbs. (90 kg)	91 lbs. (41 kg)	290 lbs. (131 kg)	199 lbs. (90 kg)	91 lbs. (41 kg)
Michelin Tires I.L.O.S.	376 lbs. (171 kg)	752 lbs. (341 kg)	1,128 lbs. (512 kg)	376 lbs. (171 kg)	752 lbs. (341 kg)
Rigging Box	172 lbs. (78 kg)	259 lbs. (117 kg)	431 lbs. (195 kg)	172 lbs. (78 kg)	259 lbs. (117 kg)

STERLING CRANE

Dimensions

Tailswing

No Counterweight - 14' 1" (4293)

"A" Counterweight - 14' 11" (4547)

"C" Counterweight - 17' (5182)

Turning Clearance

Over Bumper - 53' 3" (16.3m)

At Curb - 51' 2-1/2" (15.6m)

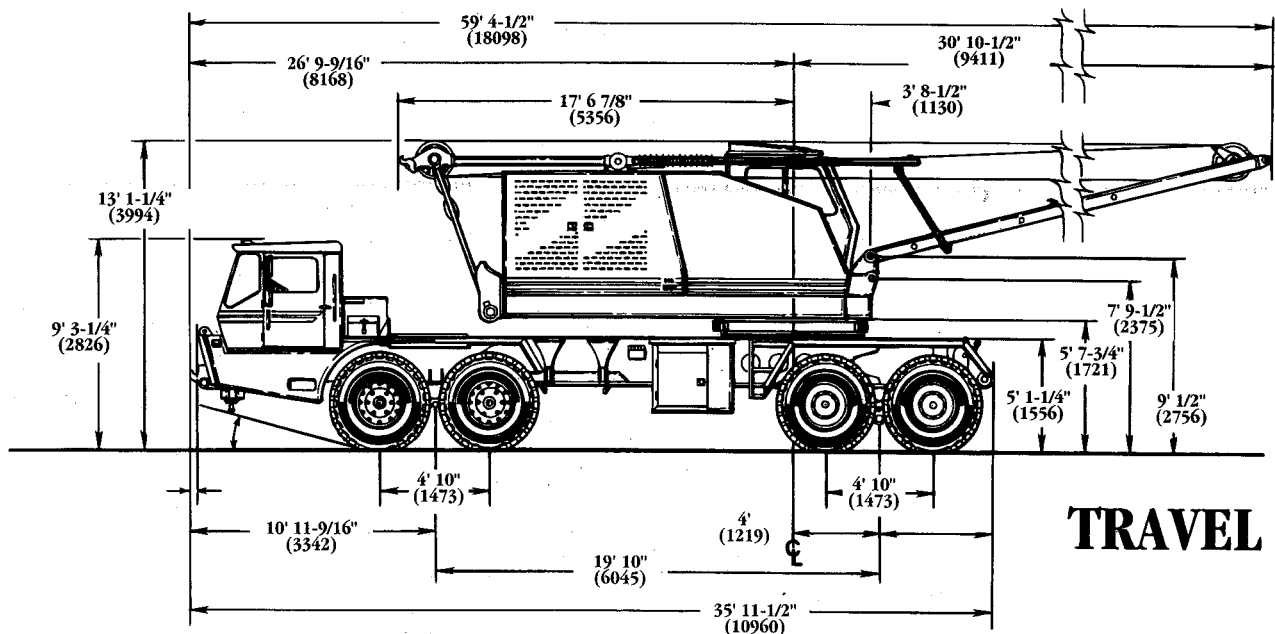
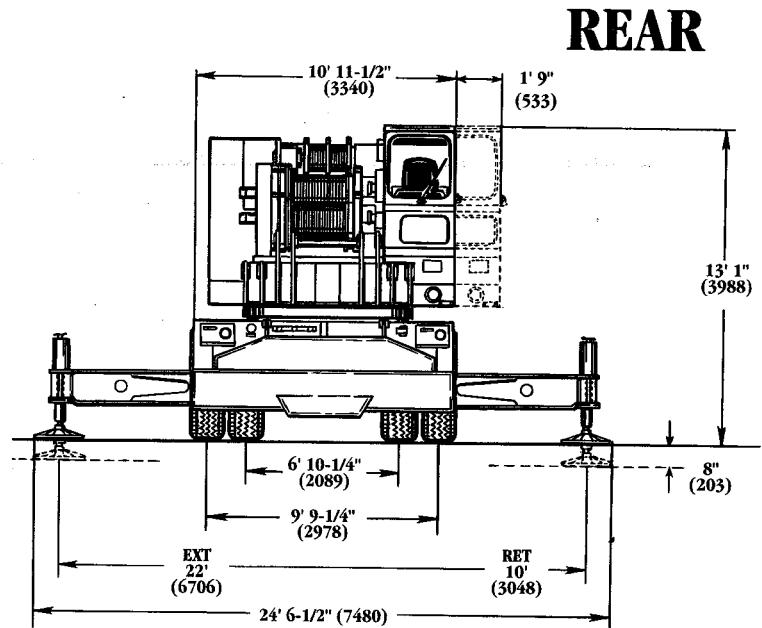

STERLING CRANE

Dimensions

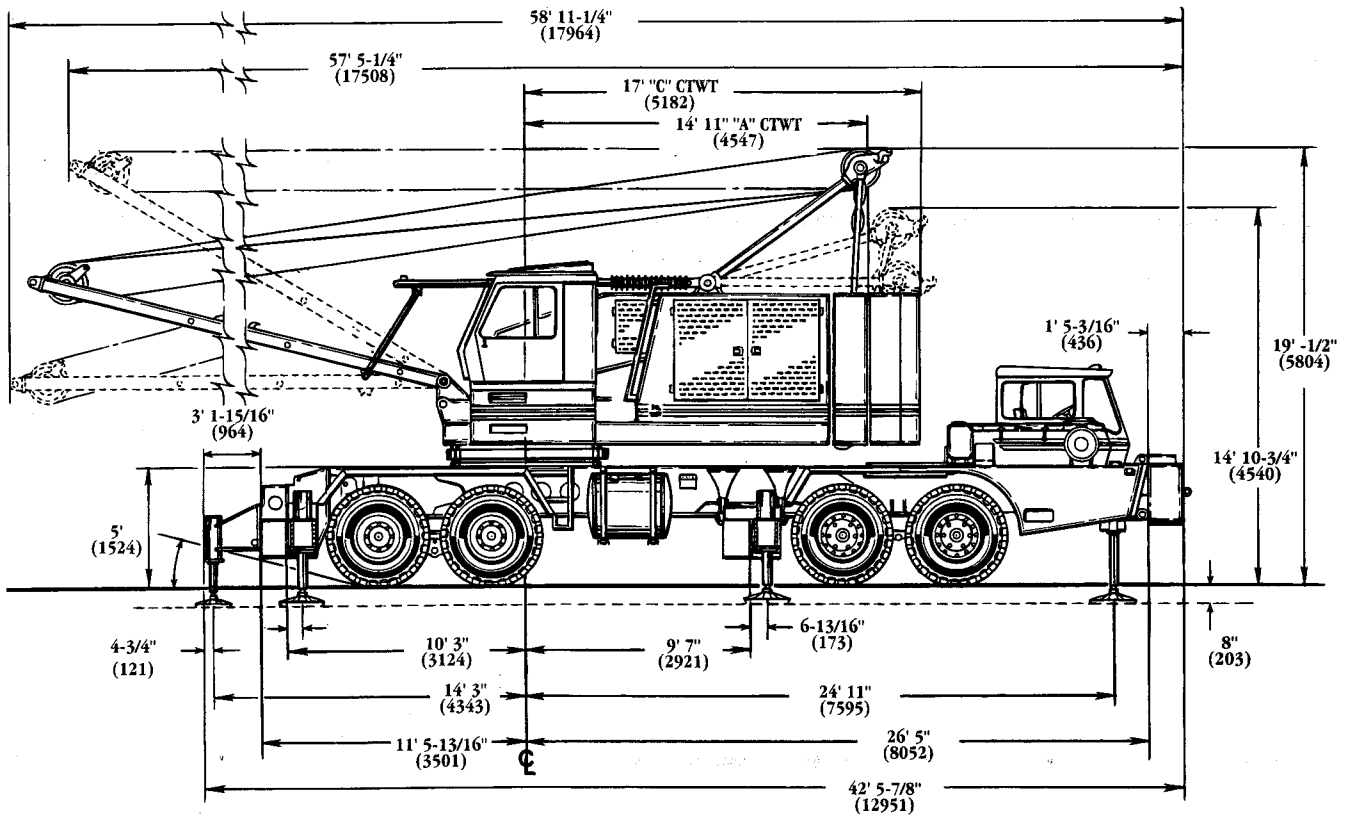

WORKING