



## LIFTING CHARTS - Crawler Cranes

### MANITOWOC MODEL 888 - 230 TON CAPACITY

#### BOOM RIGGING GUIDE MODEL 888 AND 999 # 22 EL BOOM

### Table of Contents

General .....	1	Install Pendants .....	8
Assist Crane Requirements .....	1	Connect Boom Butt to Boom .....	9
Accessing Parts .....	2	Remove Lower Boom Point Sheaves .....	9
Installation and Removal Notes .....	2	Install Upper Boom Point .....	9
Retaining Connecting Pins .....	3	Install Jib .....	10
Blocked Crawler .....	3	Install Load Line .....	10
Handling Components .....	3	Install Block-Up Limit Control .....	10
Boom Rigging Assembly Drawing .....	4	Pre-Raising Checks .....	10
Identifying Boom Sections and Pendants .....	4	Boom Removal .....	11
Boom Installation .....	5		
Assemble Boom .....	7		

### General

This folio contains installation and removal instructions for all parts of the boom except the boom butt. Boom butt installation and removal instructions are contained in the Crane Assembly Guide in Operator’s Manual.

Refer to the Jib Rigging Guide in Operator’s Manual for jib installation and removal instructions.

This folio contains all the requirements that are necessary for the boom to be made to order by the specified date and time.

### Assist Crane Requirements

An assist crane is not required to assemble and disassemble the boom components. The 888 can be used to assemble and disassemble its own boom. Refer to the Crane Weights folio in crane Operator’s Manual for weights of boom components.

The 888 must be in the following configuration to assemble its own boom and jib (Figure 1):

- Crawlers extended.
- Counterweight installed.
- Gantry fully raised.
- Mast assist arms fully raised.
- Crane setup mode selected and confirmed.
- Mast operated between fully extended mast arms and 150° (29 ft [8.8 m] radius). Mast angles measured from transport position which is 0°.
- Capacity limited to 50,000 lb (22 680 kg).

# STERLING CRANE

## BOOM RIGGING GUIDE

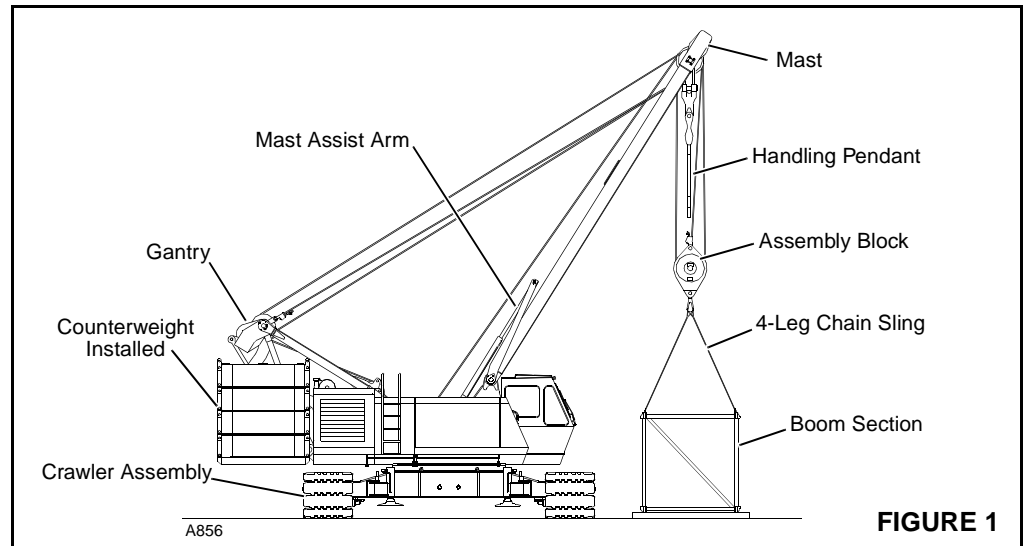

### Accessing Parts

Some parts of crane and attachment cannot be reached from the ground. Take necessary precautions to prevent falling off crane and attachment during component installation and removal.

Owner/user must provide workers with approved ladders or personnel hoists in order to access those areas of crane and attachment that cannot be reached from the ground. Adhere to all regulatory safety standards.

### Installation and Removal Notes

The boom shall be installed and removed by experienced personnel trained in erection and operation of construction cranes.

Read and become thoroughly familiar with instructions in this folio before attempting to install or remove the boom.

Contact Service Department at factory for assistance if any procedure is not fully understood.

The installation/removal area must be firm, level, and free of ground and overhead obstructions. The area selected must be large enough to accommodate the selected length of boom and jib (if attached), in addition to movement of the 888.

### WARNING



**Read Capacity Charts!** Crane must be rigged and operated according to instructions in capacity charts provided with crane. Failing to comply with instructions in capacity charts and in this folio can result in tipping or structural failure of boom and jib.

### Retaining Connecting Pins

All connecting pins are retained with either cotter pins or keeper plates.

Do not operate crane until:

- All cotter pins are installed and opened.
- All keeper plates are installed and connecting screws are securely tightened.

### Blocked Crawler

To prevent crane from tipping, some boom and jib lengths must be raised and lowered over blocked crawlers. Refer to capacity charts for blocked crawler requirements and to Crawler Blocking Diagram folio in Operator's Manual for instructions.

---

#### DANGER



**Tipping Hazard!** Do not attempt to raise or lower boom and jib from or to ground until crawlers are blocked, if required. Otherwise, crane will tip.

---

### Handling Components

Handle boom sections with care to avoid damaging lacings and chords. *Lift against chords only, never against lacings.*

Nylon slings should be used to handle boom sections. If wire rope or chain slings are used, protective covering (such as sections of rubber tire) must be used between the slings and section.

Boom handling with handling pendants from mast pinned to lower rope guide links on boom butt is limited. See chart in Figure 2.

**NOTE:** Stowable pendants are from either 22E or 22C boom.

---

#### WARNING



**Falling Boom Hazard!** Do not attempt to handle more boom with mast than shown in Figure 2. Structural failure of components could result, possibly allowing boom to fall.

# STERLING CRANE

## BOOM RIGGING GUIDE

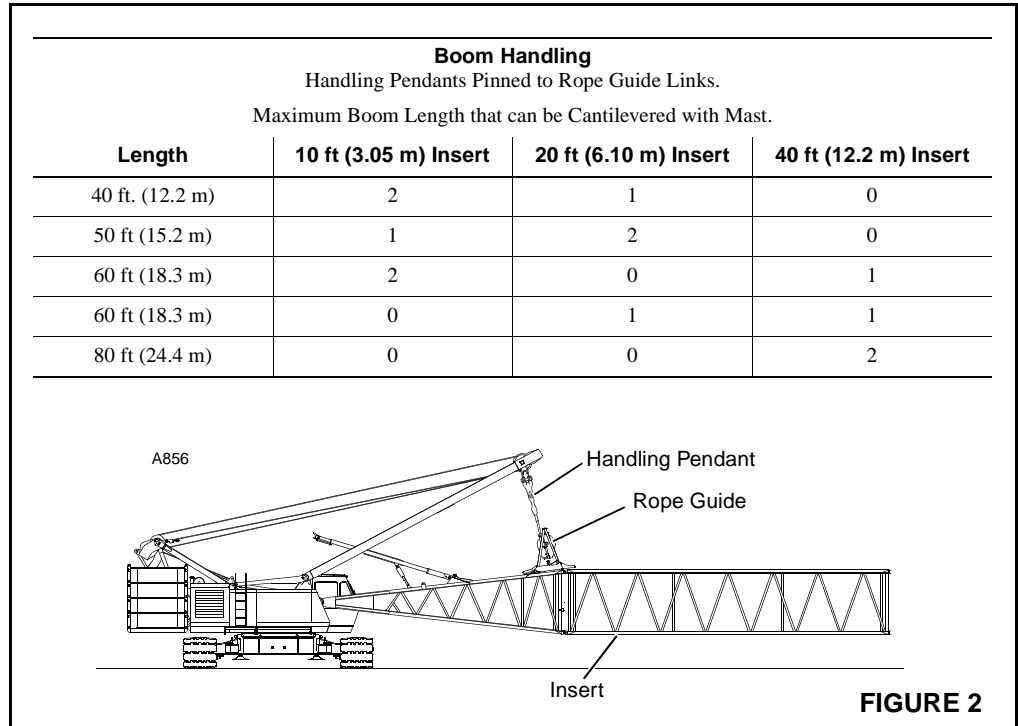

**FIGURE 2**

## Boom Rigging Assembly Drawing

Boom components (top, inserts, butt, pendants) must be assembled in proper sequence according to this folio and Boom Rigging Assembly drawing in Operator's manual. Refer to Figure 6 to determine quantity and length of inserts and pendants for various boom lengths.

A minimum boom length of 90 ft. (27.4 m) is required for jib attachment (refer to Liftcrane Jib Capacity charts for boom and jib length limitations).

Either non-stowable pendants (from 4100W #22 boom rigging) or stowable pendants can be used to assemble the #22EL boom.

The stowable pendants are slightly longer than the non-stowable pendants. When disassembling the boom, the stowable pendants can be disconnected and left on top of the inserts for shipping. This arrangement allows the boom to be reassembled faster.

Stowable pendant connectors are painted a contrasting color to differentiate them from non-stowable pendants.

***It is owner/user's responsibility to securely attach stowable pendants to inserts so that pendants cannot fall off inserts during shipment.***

## Identifying Boom Sections and Pendants

Boom sections are marked for proper identification as shown in Figure 3, View A.

**Past Production Boom** — Boom number, part number, and manufacturing code are stamped into two connectors (diagonally opposite) on both ends of each insert and on end of top and butt.

**Current Production Boom** — Boom number, part number, and manufacturing code are stamped into a plate mounted on all four chords of each section.

Pendants are marked for proper identification as shown in Figure 3, View B.

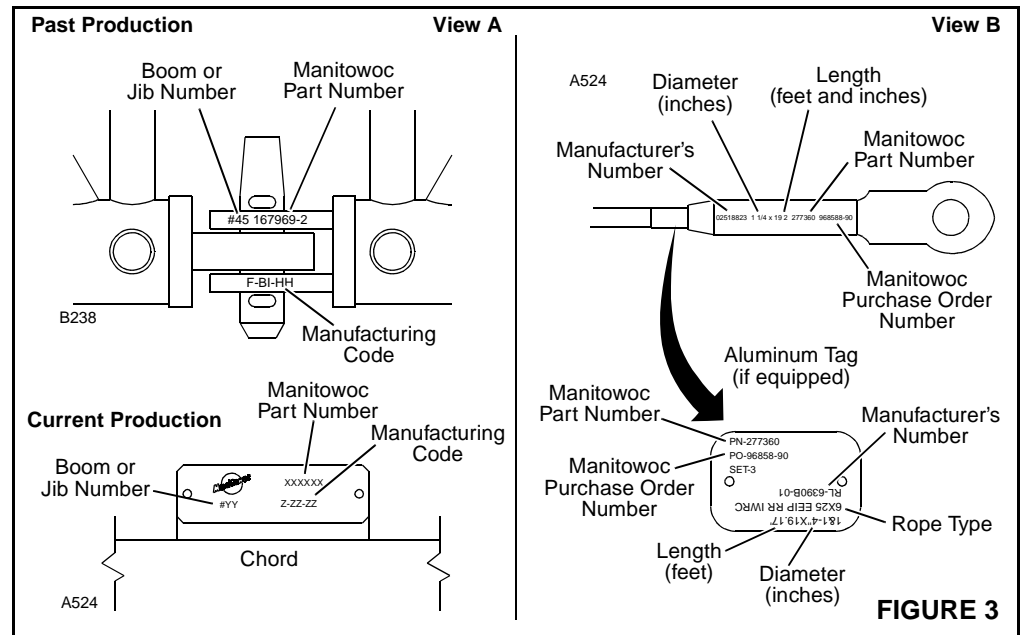

## Boom Installation

The crane must be in the setup mode as shown in Figure 1 to assemble its own boom.

### WARNING



**Falling load Hazard!** Prevent crane from tipping, wire rope from breaking, or mast from collapsing:

- Do not exceed 29 ft (8.8 m) radius. Wire rope will hit lacing in mast.
- Do not lift more than 50,000 lb (22 680 kg). Tipping or structural damage to mast may occur.

### WARNING



**Collapsing Boom Hazard!** To prevent death or serious injury, do not stand on, inside, or under boom during assembly. Always stand outside of boom when installing connecting pins.

# STERLING CRANE

## BOOM RIGGING GUIDE

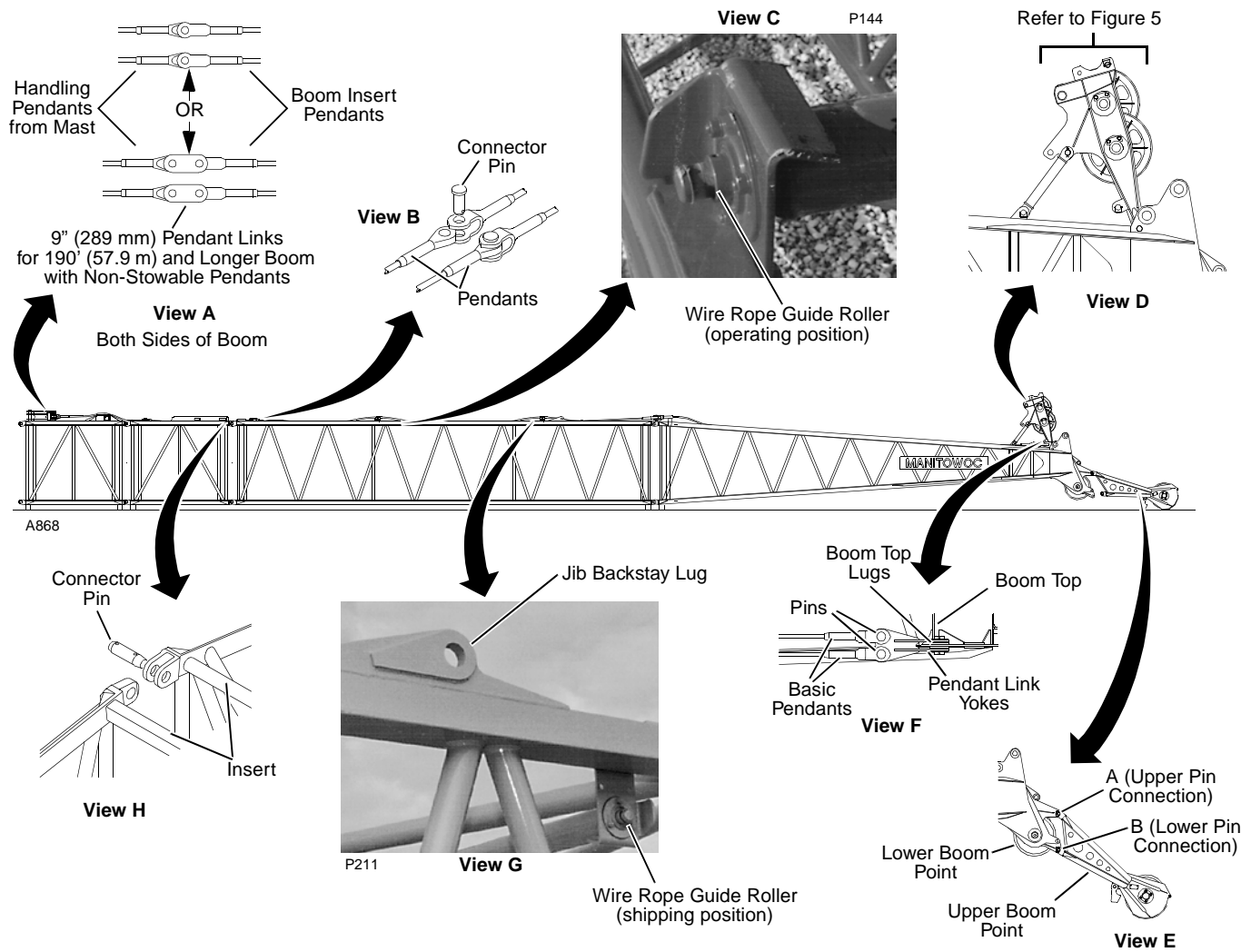

FIGURE 4

### Assemble Boom

1. Place boom top on blocking (Figure 4):
  - 4 – 6 in. (102 – 152 mm) high under bottom connectors.
  - As required under boom point so centerline of top is level.
2. Pin inserts — in proper sequence — to boom top and to each other.
  - Wire rope rollers on inserts must face up. If wire rope rollers were shipped upside down (Figure 4, View G), unscrew and reattach brackets so rollers are right side up (Figure 4, View C).
  - If jib will be installed, insert with jib backstay lugs must be installed next to boom top.
  - Pin inserts to top and to each other as shown in Figure 4, View H.
  - Block below bottom insert connectors as inserts are pinned in place.
3. Install upper wire rope guide (Figure 5, View A), as follows:
  - a. Lift wire rope guide into position over boom top.
  - b. Align connecting holes in lower wire rope guide frame and struts with connecting holes in mounting lugs and attach with pins and snap pins (Figure 5, View A) to boom top.
    - Sheave A location is for rope from front or rear drum to lower boom point sheave.
    - Sheave B location is for rope from front or auxiliary drum to upper boom point, jib point, or lower boom point sheave.

**NOTE:** Lower wire rope guide assembly is shipped assembled. Refer to Load Line Reeving Instruction for proper reeving of load lines.

- c. If equipped and or required, mount upper wire rope guide on lower wire rope guide assembly using snap pins, roller, flat washer and cotter pins (Figure 5, View B).
  - Sheave C location is for line to lower boom point (Figure 5, View B).

# STERLING CRANE

## BOOM RIGGING GUIDE

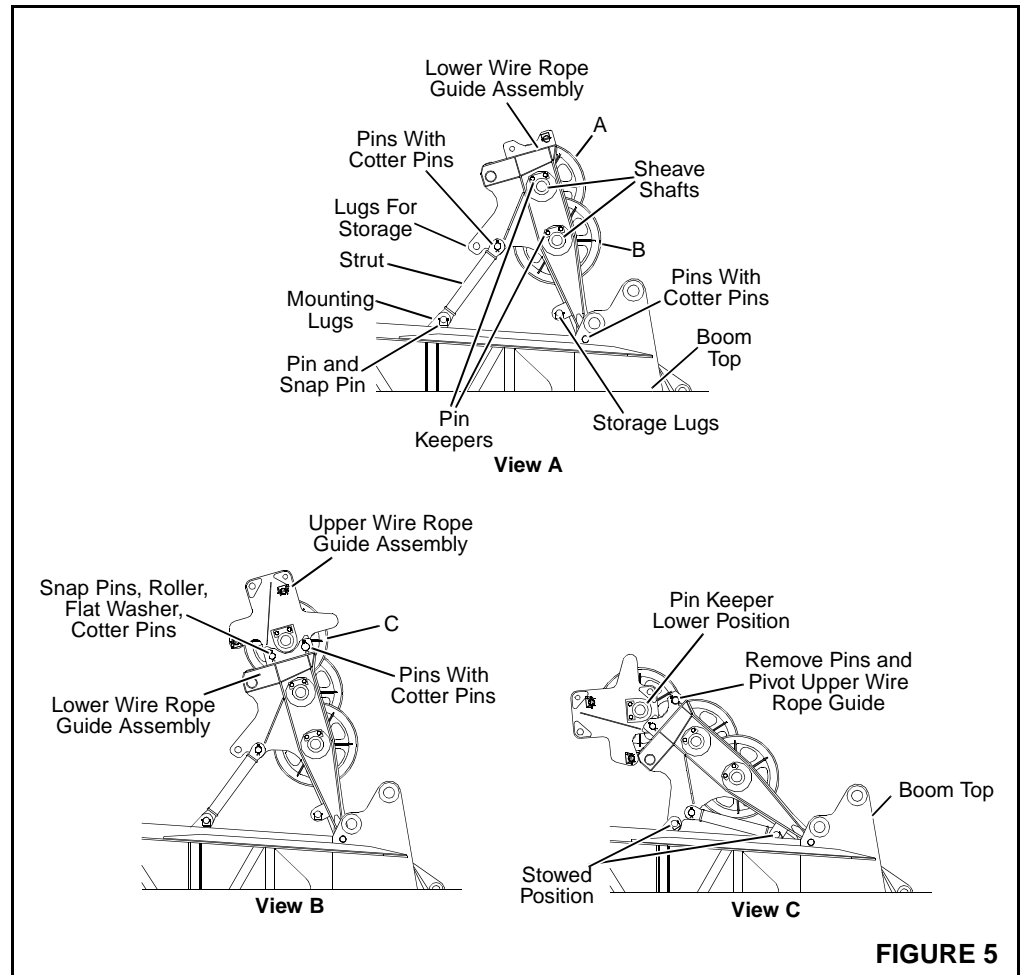

## Install Pendants

### WARNING



**Falling Boom Hazard!** Starting at butt end of boom, pendants must be installed in same sequence as inserts (shortest inserts and pendants nearest butt).

Pendants are furnished in matched sets of four and must be installed in matched sets — two pendants on one side of insert must match two pendants on opposite side of insert.

Do not mix stowable pendants with non-stowable pendants.

Failing to comply with these precautions can result in severe side loading of boom and mast. Structural damage to boom and mast could occur, possibly causing boom to collapse.

1. Pin pendant links to lower lugs on boom top. Pin basic pendants to pendant links. (Figure 4, View F).
2. Stretch basic pendants tightly along top of boom and *tie them to boom so they cannot fall off*.

3. Pin remaining pendants in proper sequence to basic pendants (Figure 6 and Figure 4, View B).
4. Stretch pendants tightly along top of boom as assembly progresses. *Tie pendants to boom so they cannot fall off inserts.*
5. *Make sure pendants are not crossed.* Pendants are side-by-side.
6. Install pendant connecting pins so heads are toward top (Figure 4, View B).
7. For 190 ft (57.9 m) and longer boom with non-stowable pendants, pin a 9 in. (289 mm) long pendant link to ends of last pendants installed (Figure 4, View A).

### **Connect Boom Butt to Boom**

Install boom butt as instructed in Crane Assembly Guide in Operator's Manual.

1. Connect boom butt to crane as instructed in Crane Assembly/Disassembly Guide, Assembly Procedure I.
2. Connect boom butt to boom as instructed in Crane Assembly/Disassembly Guide, Assembly Procedure J.
3. Connect handling pendants from mast to last set of boom pendants or to links on last set of boom pendants (Figure 4, View A).
4. Untie pendants from boom before raising mast (booming up).

### **Remove Lower Boom Point Sheaves**

If required, some sheave clusters and shafts may have to be removed and replaced with spacers and shims. Refer to Lower Boom Point Assembly Installation Instruction.

### **Install Upper Boom Point**

If required, install upper boom point as follows:

1. Lift upper boom point into position at end of boom top.
2. Align upper boom point holes to boom top holes at A and install connecting pins and snap pins. Do not pin lower holes. This will allow upper boom point to rest on blocking (Figure 4, View E).
3. Install connecting pins and snap pins at holes B after upper boom point is clear of ground (Figure 4, View D).

## BOOM RIGGING GUIDE

---

### Install Jib

Upper boom point must be removed prior to jib installation. See Jib Rigging Guide in Operator's manual for jib installation instructions.

### Install Load Line

Refer to Load Line Reeving folio in Operator's manual for proper routing and reeving of load lines.

### Install Block-Up Limit Control

Refer to Block-Up Limit Switch Adjustment folio in Operator's Manual for block-up limit control installation and adjustment instructions.

## Pre-Raising Checks



---

### DANGER

**Falling Mast/Boom Hazard!** Prevent mast and boom from collapsing:

- Fully lower mast assist arms before raising boom. Mast will buckle and collapse if it contacts arms with a fully rigged boom attached.

---

Perform pre-raising checks given in Crane Assembly/Disassembly Guide before raising boom.

### Boom Removal

Refer to Crane Assembly/Disassembly Guide in Operator's Manual and perform disassembly steps A through E to remove the boom. Removal is basically the reverse of installation.

***It is owner/user's responsibility to securely attach stowable pendants to inserts so that pendants cannot fall off inserts during shipment.***

Upper wire rope guide assembly can be stowed as follows for shipping (Figure 5, View C):

- Use an assist crane to hold wire rope guide upright.
- Remove pins and snap pins from struts attached to mounting lugs (Figure 5, View A). Reattach to lugs on lower wire rope guide frame.
- Remove pins and pivot upper wire rope guide assembly so that upper wire rope guide assembly rests against lower wire rope guide assembly

## BOOM RIGGING GUIDE

22EL BOOM IDENTIFICATION	
Item	Description
1 <sup>d</sup>	30' (9.14 m) Butt
1	30' (9.14 m) Butt
2	40' (12.19 m) Top
3 <sup>ad</sup>	10' (3.05 m) Insert
3 <sup>a</sup>	10' (3.05 m) Insert
4 <sup>a</sup>	20' (6.1 m) Insert with or without Jib Backstay Lugs <sup>b</sup>
5	40' (12.19 m) Insert with or without Jib Backstay Lugs <sup>b</sup>

22 EL PENDANT IDENTIFICATION		
Item	Description	Optional
6	36' 6" (11.1 m) Basic	
7 <sup>c</sup>	10' (3.05 m) Insert	
8 <sup>c</sup>	20' (6.1 m) Insert	20' 1-1/2" (6.13 m) Insert
9 <sup>c</sup>	40' (12.19 m) Insert	40' 3" (12.27 m) Insert

- a Maximum number of inserts (item 3) is two.  
 Maximum number of inserts (item 4) is two.  
 Combination of inserts (item 3 and 4) must not exceed:
- Two inserts (item 3) and one insert (item 4) or
  - One insert (item 3) and two inserts (item 4).
- b Insert with jib backstay lug must be installed nearest to top, if jib will be used.
- c Pendants come in matched sets of four (two on each side of boom).
- d For use with auxiliary drum shaft assembly, if equipped. Use boom butt and 10' (3.05 m) insert with drum shaft/wire rope guide. Ten foot (3.05 m) insert with rope guide must be next to butt. Minimum boom length using these components is 80' (24.38 m).

M= Connect to Handling Pendants on Mast

FIGURE 6

# STERLING CRANE

## BOOM RIGGING GUIDE

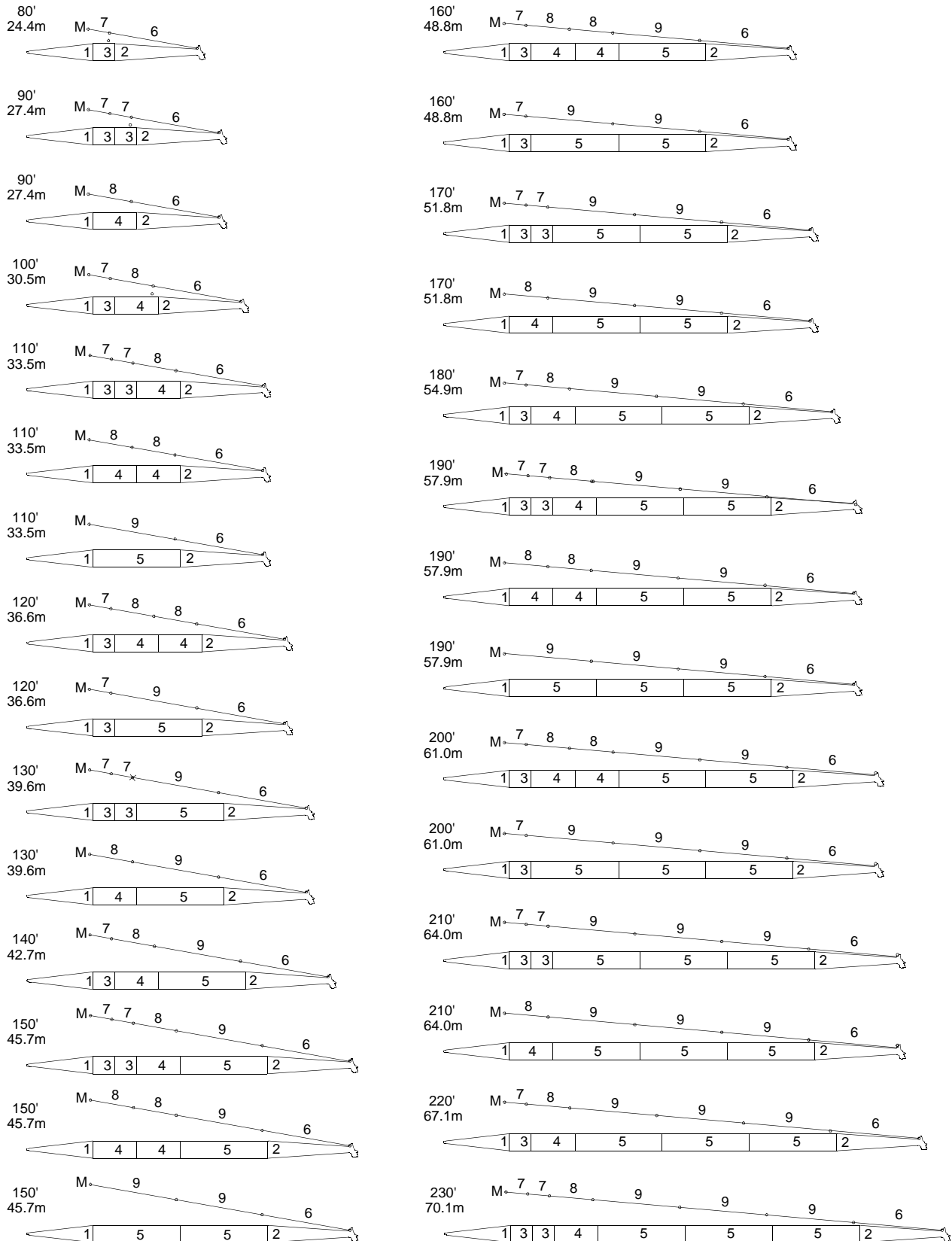

FIGURE 7

# STERLING CRANE

## BOOM RIGGING GUIDE

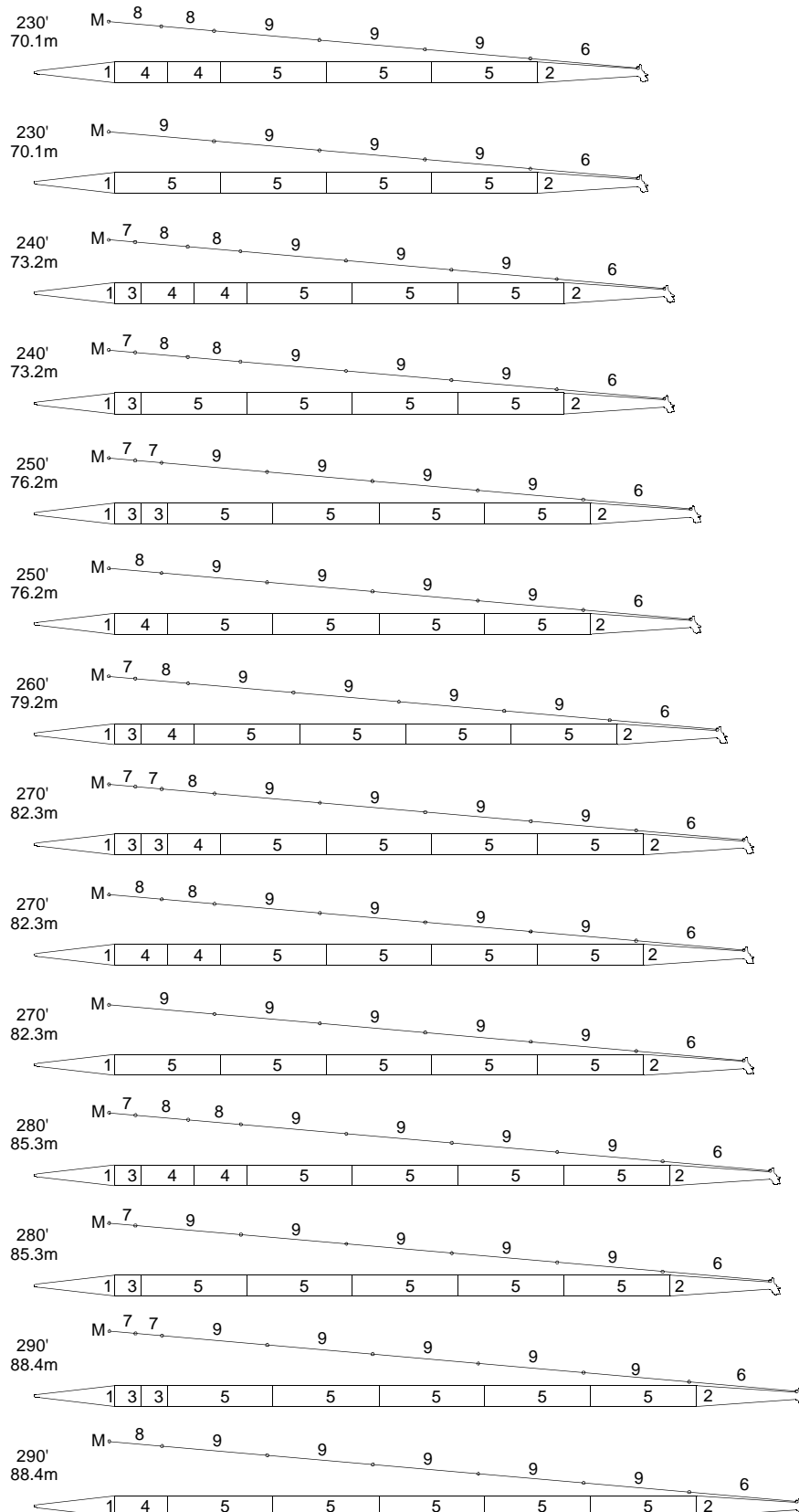

FIGURE 8