



TRANSPORTATION SPECS - All Terrain Cranes

DEMAG MODEL AC 205 - 100 TON CAPACITY

COMPONENT WEIGHTS

	<u>LBS.</u>	<u>KGS.</u>
Complete Crane (incl. block, ball, jib & max. cwt.)	132,956	60 309
Main Unit c/w Outriggers (1) (incl. 22T block, ball, jib & 6.8T cwt.)	107,163	48 609
Main Unit c/w Outriggers & Jib (2) (excl. cwt)	92,348	41 889
Counterweight – Min.	11,244	5 100
Counterweight – Max.	39,683	18 000
Certificate Weight		40 000

ADDITIONAL INFORMATION

	<u>LBS.</u>	<u>KGS.</u>
80 Ton Block, 5 Sheave	1,433	650
20 Ton Block, 1 Sheave	772	350
5 Ton Ball	250	113
30' – 58' 2 Stage Jib	2,400	1 089
Spare Tire	882	400
Main Load Line (18 mm x 210 M)	741	336
Auxiliary Load Line (18 mm x 210 M)	741	336

COUNTERWEIGHT

	<u>LBS.</u>	<u>KGS.</u>
Large Upper Left (Bolted)	4,188	1 900
Large Upper Right (Bolted)	3,748	1 700
Upper Small (Bolted) (2) each	1,543	700
Basic Top Slab	3,748	1 700
Basic Bottom Slab	2,646	1 200
Interm. Upper Slab	7,606	3 450
Interm. Center Slab (2) each	4,410	2 000
Interm. Lower Slab	5,622	2 550

TRANSPORTATION

Average Driving Speed 70 km/hr

Alberta and Saskatchewan

	<u>Weight</u>	<u>Trailer</u>
Spring	(1)	48 wh
Summer	(1)	36 wh
Winter	(1)	32 wh

British Columbia

Lower Mainland (2) 7–8 axle

All Provinces / All Seasons

	<u>No</u>	<u>Trailer</u>
21,385lb. cwt. & misc.	1	Tandem

STERLING CRANE

Dimensions

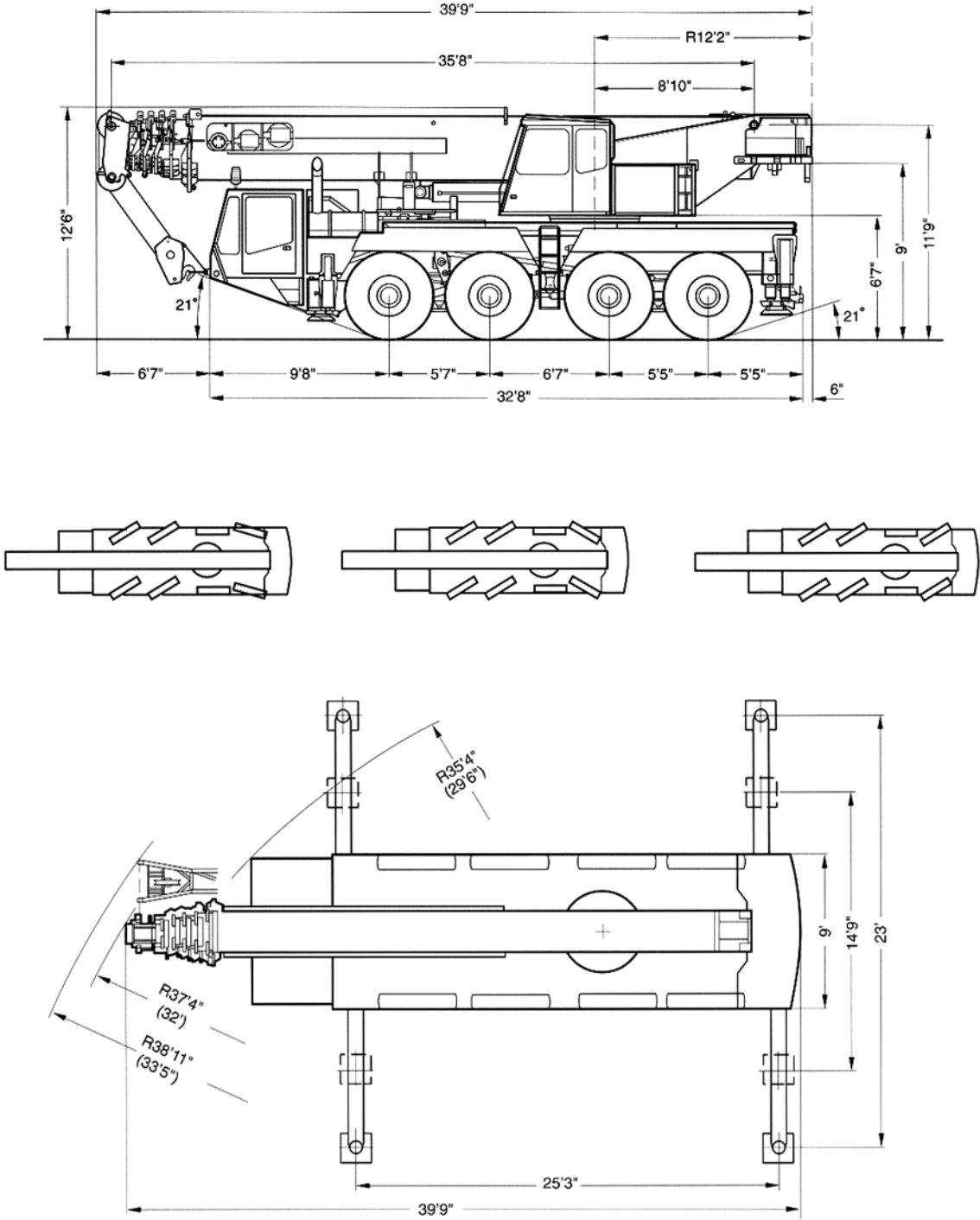

() with independent rear axle steering, 3rd axle raised