



## TRANSPORTATION SPECS - All Terrain Cranes

### LIEBHERR MODEL LTM 1090/2 - 110 TON CAPACITY

<b><u>COMPONENT WEIGHTS</u></b>	<b><u>LBS.</u></b>	<b><u>KGS.</u></b>
Complete Crane c/w Full Counterweight and Block	142,771	64,761
House, Carrier and Boom - 45'6" / 33'10" x 8'10" x 13'1"	96,500	42 772
<b><u>Counterweights</u></b>		
1.2 t Counterweight - 8'10" x 4'9" x ??	2,645	1 200
1.2t Counterweight - 8'10" x 4'9" x ??	2,645	1 200
2.0t Counterweight - 8'10" x 4'9" x 4"	4,409	2 000
3.2t Counterweight - 8'10" x 4'9" x 6'	7,055	3 200
4.6t Counterweight - 8'10" x 4'9" x 9" - 8'10" x 4'9" x 11"	10,141	4 600
7.8t Counterweight - 11'6" x 5'5" x 1'7"	17,196	7 800
Total Counterweight	44,091	20 000
<b><u>ADDITIONAL WEIGHTS</u></b>		
70 t 5 Sheave Block	1,760	798
50 t 3 Sheave Block	990	449
7.5 t Ball	420	191
Swingaway Jib 10.8–19m (35 – 62') - 35'5" x 3'11" x 2'8"	3,699	1 678
Tire Size 16.0R25		

# STERLING CRANE

## DIMENSIONS

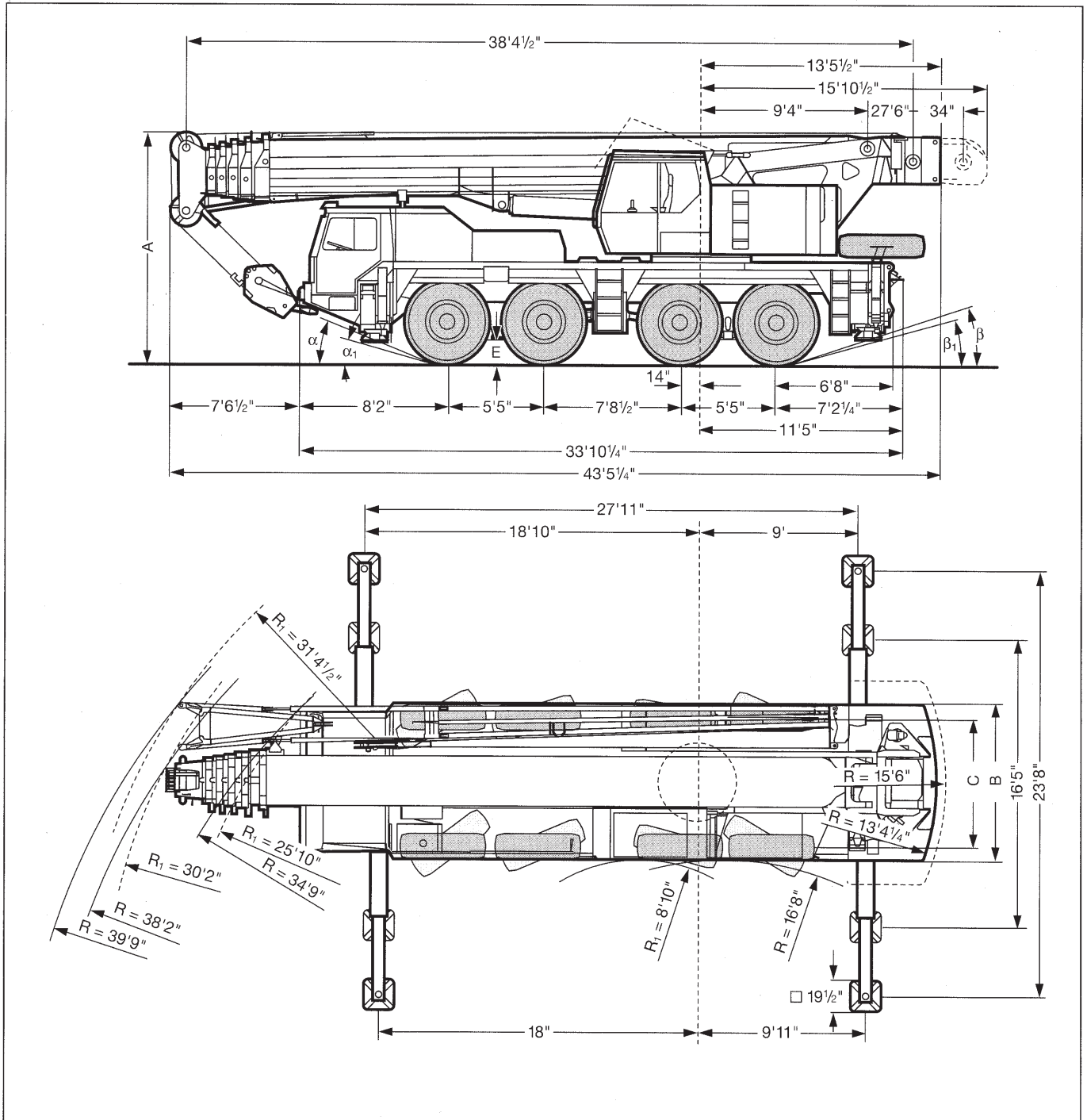

	Dimensions / Encombrement								
	A	A 6''*	B	C	E	$\alpha$	$\alpha_1$	$\beta$	$\beta_1$
<b>16.00 R 25</b>	12'9 1/2"	12'5 1/2"	7'4"	8'9 1/2"	17"	22°	17°	18°	14°

\* lowered / abaissé