



## TRANSPORTATION SPECS - Boom Trucks

### MANITOWOC MODEL 30124C - 30 TON CAPACITY

#### COMPONENT WEIGHTS

	<u>LBS.</u>	<u>KGS.</u>
Complete Crane & Truck (Unit 30-7-1239)	52,140	23 700
Crane Only With Fixed Jib	29,150	13 250

#### ADDITIONAL INFORMATION

31' Fixed Jib	850	386
30 Ton Block	430	195
7 Ton Ball	172	78
8' x 22'4" Deck	2,000	909

#### TRANSPORTATION

Average Driving Speed 80 km/hr

#### Alberta, BC, Ontario and Saskatchewan

• Spring	Drive	-
• Summer	Drive	-
• Winter	Drive	-

# STERLING CRANE

## outline dimensions

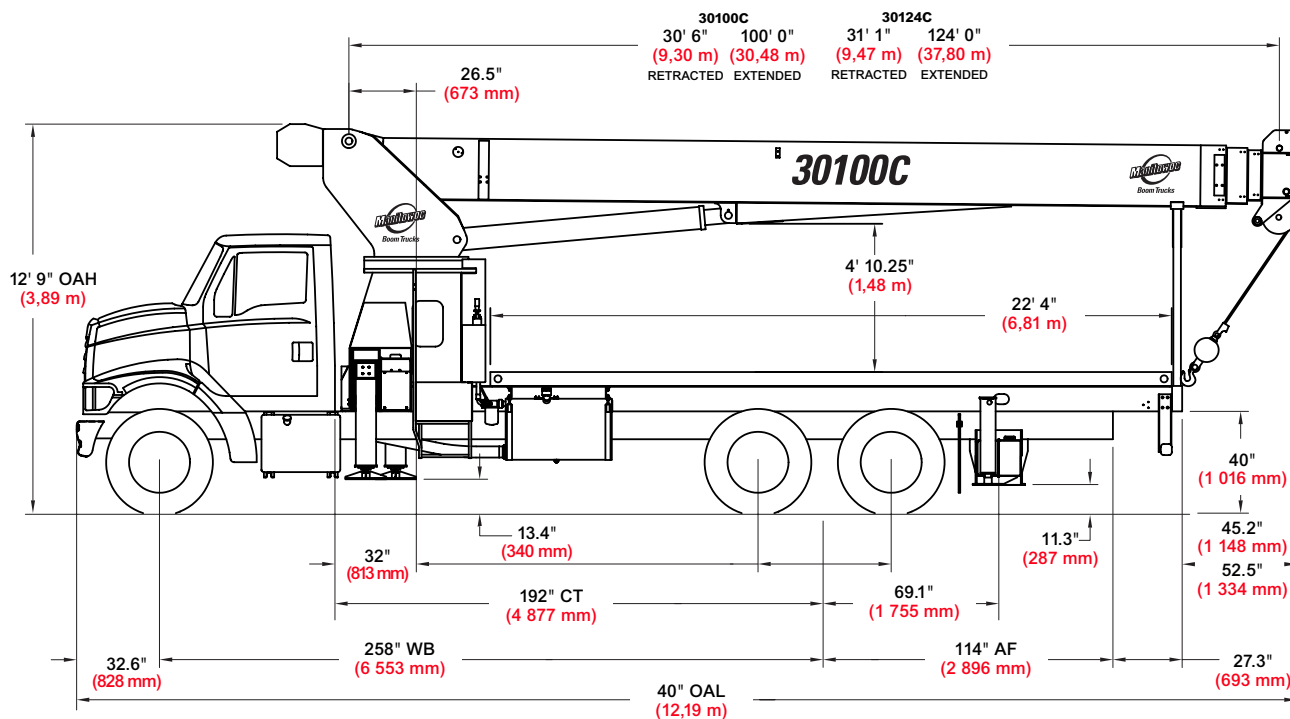

### Chassis Data

Minimum Truck Requirements	30100C	30124C
<b>Wheelbase (WB)</b>	<b>258" (6 553 mm)</b>	<b>258" (6 553 mm)</b>
<b>Cab to Tandem (CT)</b>	<b>192" (4 877 mm)</b>	<b>192" (4 877 mm)</b>
<b>After Frame (AF)</b>	<b>114" (2 896 mm)</b>	<b>114" (2 896 mm)</b>
<b>Frame Section Modulus at 180° Area of Operation</b>	<b>25.0 in<sup>3</sup> 110,000 psi (758 450 kPa)</b>	<b>25.0 in<sup>3</sup> 110,000 psi (758 450 kPa)</b>
<b>Frame Section Modulus at 360° Area of Operation*</b>	<b>33.0 in<sup>3</sup> 110,000 psi (758 450 kPa)</b>	<b>33.0 in<sup>3</sup> 110,000 psi (758 450 kPa)</b>
<b>Front Axle Gross Weight Rating</b>	<b>18,000 lb (8 165 kg)</b>	<b>18,000 lb (8 165 kg)</b>
<b>Rear Axle Gross Weight Rating</b>	<b>40,000 lb (18 144 kg)</b>	<b>40,000 lb (18 144 kg)</b>
<b>Minimum Truck Axle Weight - Front**</b>	<b>8,100 lb (3 674 kg)</b>	<b>9,200 lb (4 173 kg)</b>
<b>Minimum Truck Axle Weight - Back**</b>	<b>8,300 lb (3 765 kg)</b>	<b>8,300 lb (3 765 kg)</b>
<b>Nominal Frame Width</b>	<b>34" (864 mm)</b>	<b>34" (864 mm)</b>

\*Frame section modules at 360° area of operation requires front bumper stabilizer.

\*\*Minimum chassis weight is required to meet 85% stability requirements.

Chassis data is general – not for engineering. Some dimensions depend on truck selection.

OAH Overall Height  
CT Cab to Tandem  
CA Cab to Axle  
WB Wheel Base  
OAL Overall Length  
BBC Bumper to Back of Cab  
AF Afterframe

### Weights

	30100C	30124C
<b>Total Crane - Out-and-Down Outriggers</b>	<b>27,166 lb (12 323 kg)</b>	<b>28,586 lb (12 967 kg)</b>
<b>22' (6,71 m) Flat Bed</b>	<b>2,000 lb (907 kg)</b>	<b>2,000 lb (907 kg)</b>
<b>30' 6" (9,30 m) Fixed Length Jib</b>	<b>1,126 lb (511 kg)</b>	—
<b>31' (9,45 m) Fixed Length Jib</b>	—	<b>850 lb (386 kg)</b>
<b>30' 6"-55' (9,30 m-16,80 m) Telescopic Jib</b>	<b>1,754 lb (796 kg)</b>	—

# STERLING CRANE

## outline dimensions

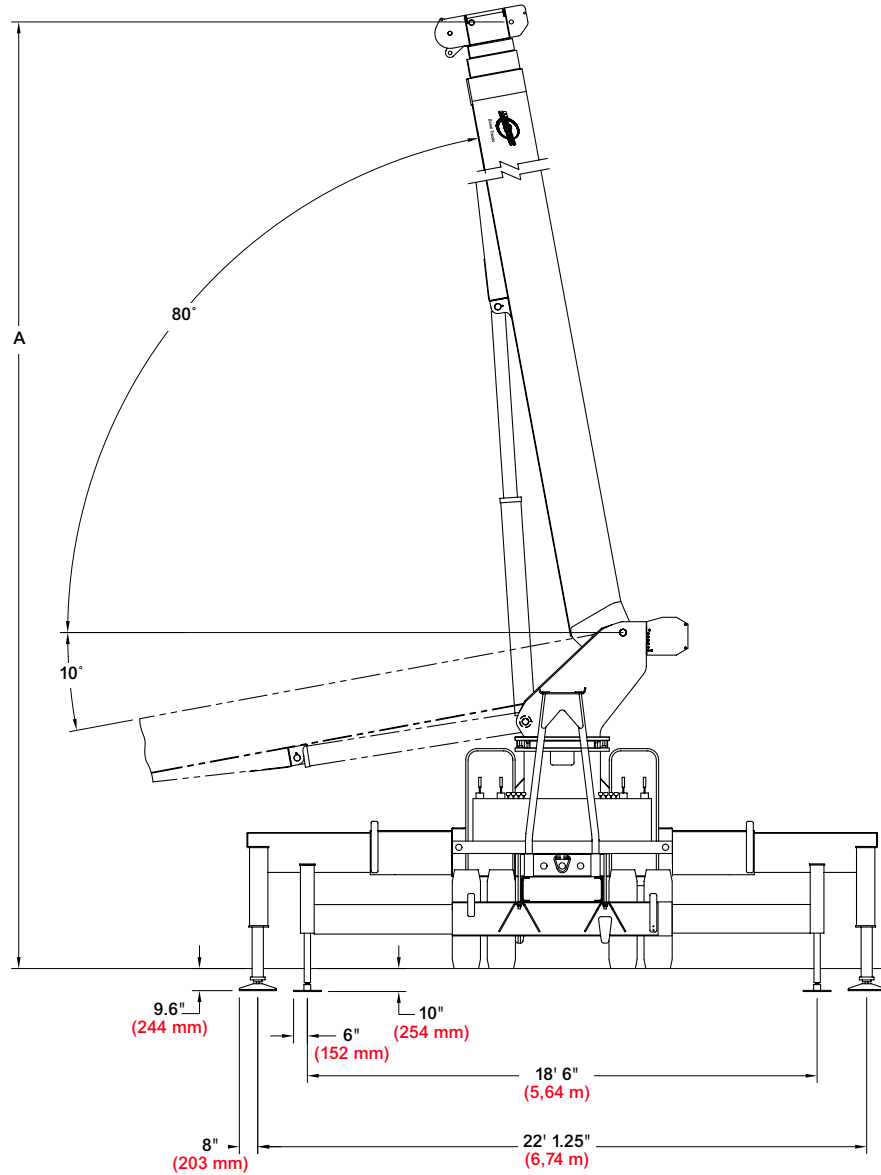

### Maximum Tip Height (A)

	30100C	30124C
Configuration	Boom 100' (30,5 m)	Boom 124' (37,8 m)
Extended Boom	111' 4" (33,9 m)	134' 8" (41,1 m)
Fixed or Retracted Jib	142' 1" (43,3 m)	165' 11" (50,6 m)
Extended Jib	166' 8" (50,8 m)	—