



TRANSPORTATION SPECS - Crawler Cranes

LIEBHERR MODEL LR 1400/1 - 440 TON CAPACITY

<u>COMPONENT WEIGHTS</u>	<u>LBS.</u>	<u>KGS.</u>	<u>Boom - Min. 21m – Max. 84m / 69' – 368'</u>			
Complete Crane c/w 69' boom, central cwt. & Block	702,351	318 584	Tubular 9'2" W x 7'10"H	<u>LBS.</u>	<u>KGS.</u>	
Superstructure c/w W4 - 39'5" x 9'10" x 6'7"	85,800	38 916	Boom Butt Section 13.4m 20'	27,557	12 500	
Carbody – 21'4" x 10' x 5'2"	34,170	15 499	Boom 7m 23' 3 pcs. Ea.	8,157	3 700	
Tracks (each) – 34'2" x 3'11" x 5'3"	59,750	27 102	Boom 14m 46' 5 pcs. Ea.	15,212	6 900	
Counterweights:			Boom Tip 7.7 m 26'	17,120	7 766	
Main:			<u>SUPERLIFT MAST – 28M (92')</u>			
Base Slab 19'8" x 8'2" x 1'3" 1 pc. Ea.	34,000	15 500	Tubular 8'2" W x 6'3"H			
10t Slab 8'2" x 5'3" x 1'6" 12 pcs. Ea.	22,046	10 000	Mast Butt 10.5m 34'5"	31,900	14 470	
Central:			Insert 7m 23'	5,940	2 694	
5.5t Slab 19'3" x 3'8" x 7" 2 pcs. Ea.	12,200	5 500	Mast Tip 10.5m 34'	13,889	6 300	
8t Slab 10'2" x 2'11" x 1'8" 4 pcs. Ea.	17,640	8 000	<u>LUFFING JIB – Min. 28m – 84m / 92' – 275'</u>			
Subtotal	392,447	178 013	Tubular 7'10" x 6'3"			
SL cwts 8'2" x 5'3" x 1'6" 22 pcs. Ea.	22,046	10 000	Butt 10.5m c/w masts 60'L x 10'10" H	31,085	14 100	
Total Counterweight	877,459	398 013	Insert 7m 23' 2 pcs. Ea.	3,748	1 700	
Counterweight Carrier 27'10"x 8'2"x 8'8"	58,700	26 626	Insert 14m 46' 4 pcs. Ea.	6,614	3 000	
Cwt Carrier Stinger 28'x 8'6"x 5'	21,000	9 526	Tip Section 11.5m 34'6"	7,275	3 300	
<u>ADDITIONAL COMPONENTS</u>						
250t 2x5 Sheave Block	17,600	7 983				
80t 3 Sheave Block	5,720	2 595				
40t Single Sheave	3,300	1 497				
12t Ball	1,320	599				
Winch W1 (3'11" x 3'11" x 3'7")	9,260	4 200				
Winch W2 (3'11" x 3'11" x 3'7")	9,260	4 200				
14' Container	10,000	4 536				
2 - Boom Install Assist Units 11'6"x2'6"x3'11" ea	1,000	453				
Boom Aux Tip 6'3"L x 2'8"H	1,200	544				

STERLING CRANE

Dimensions Encombrement

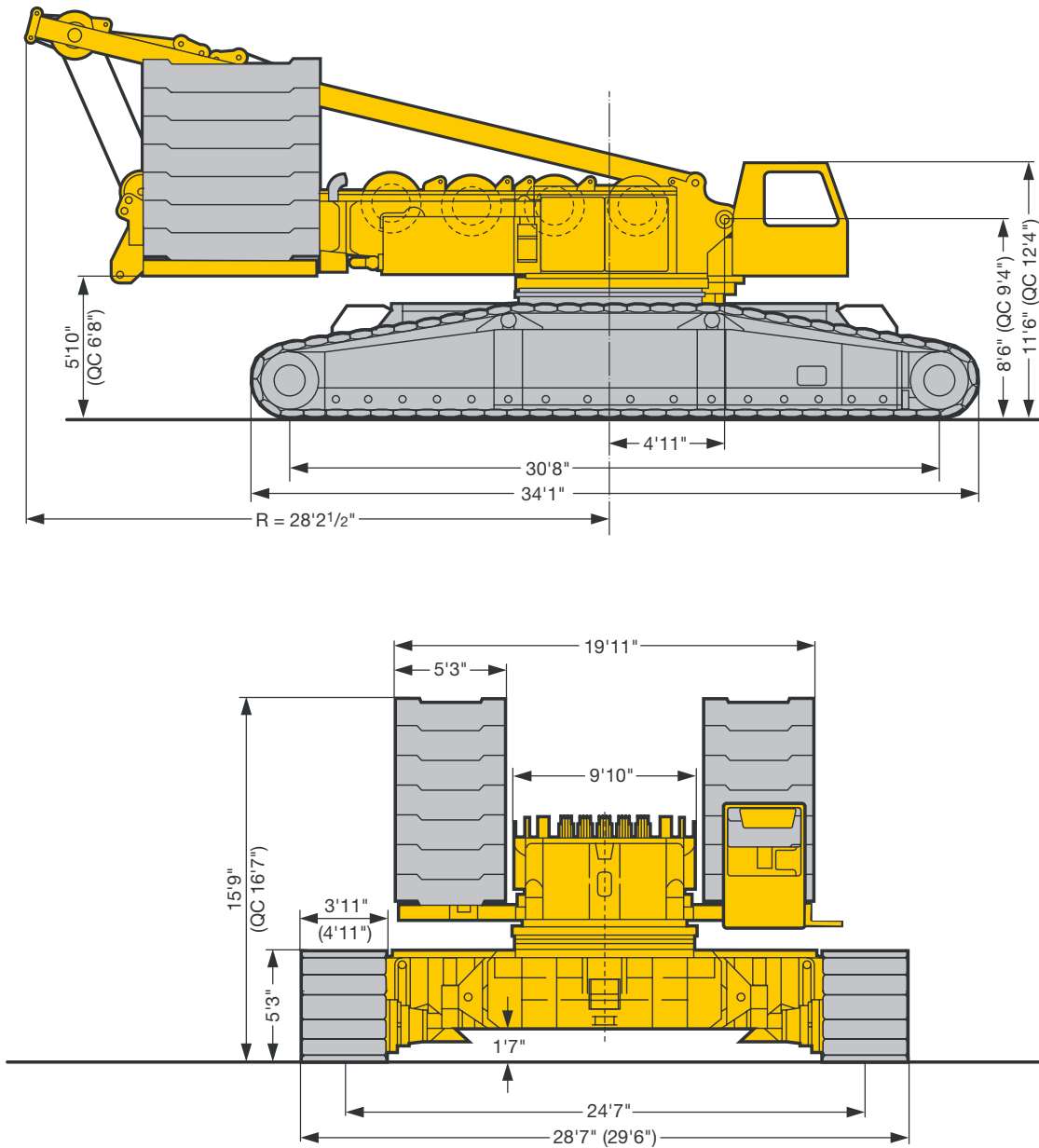

S1526

() Pad width 4'11" / Largeur de patin 4'11"

QC = Quick connection

STERLING CRANE

Transportation plan

Superstructure with winch IV incl. rope and Quick Connection
Partie tournante avec treuil IV incl. câble et dispositif de liaison

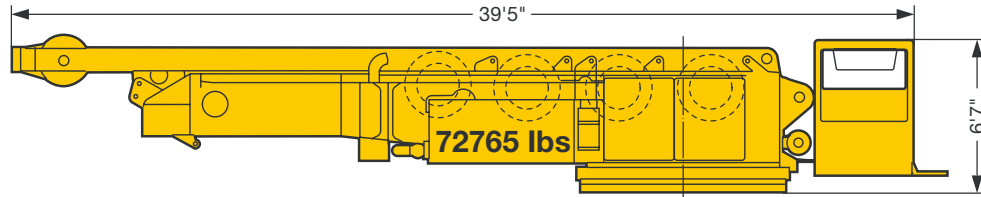

Superstructure with winch IV incl. rope and center section without Quick Connection
Partie tournante avec treuil IV incl. câble et partie centrale sans dispositif de liaison

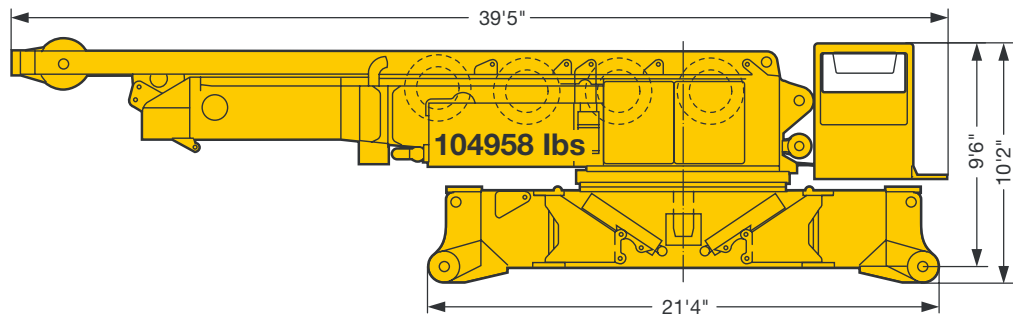

Crawler center section with Quick Connection
Partie centrale avec dispositif de liaison

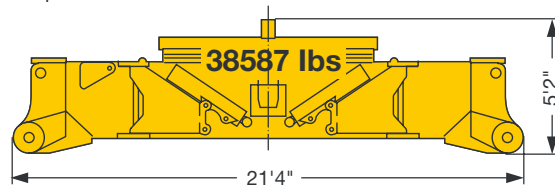

Winch 1/2 incl. rops
Treuil 1/2 incl. câble

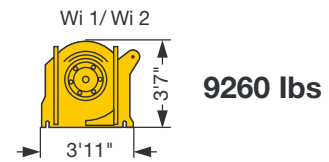

Crawler
Chenille

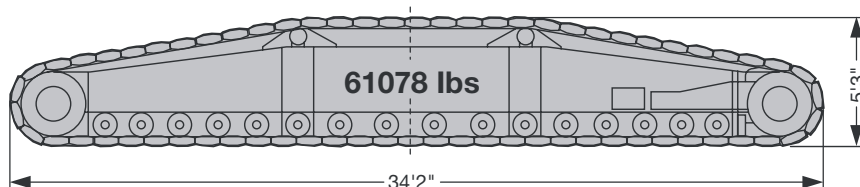

Wi = winch/treuil

S1530

STERLING CRANE

Transportation plan Plan de transport

Counterweight versions
Variantes de contrepoids

CWT at superstructure
Contrepoids tourelle

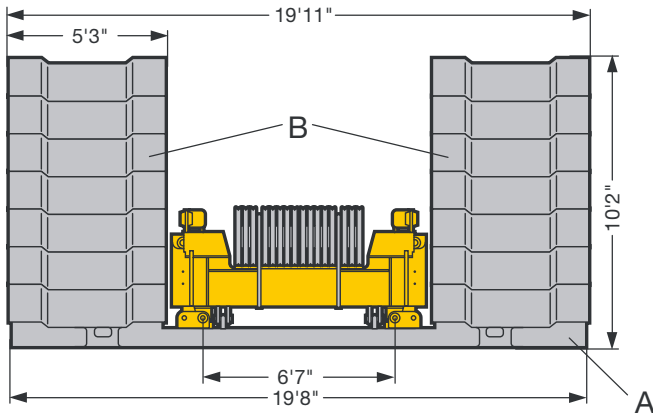

Central CWT
Lest central

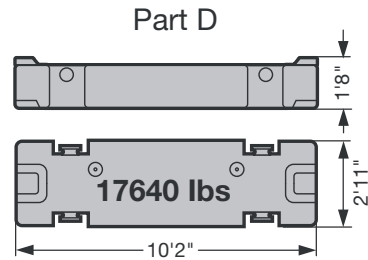
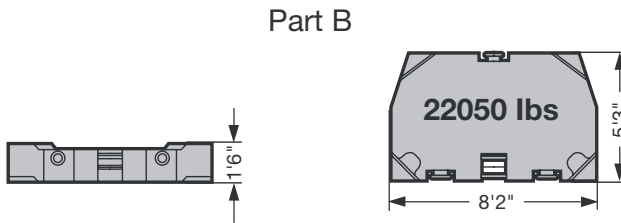
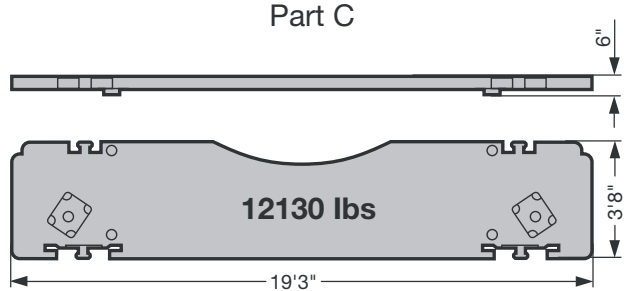
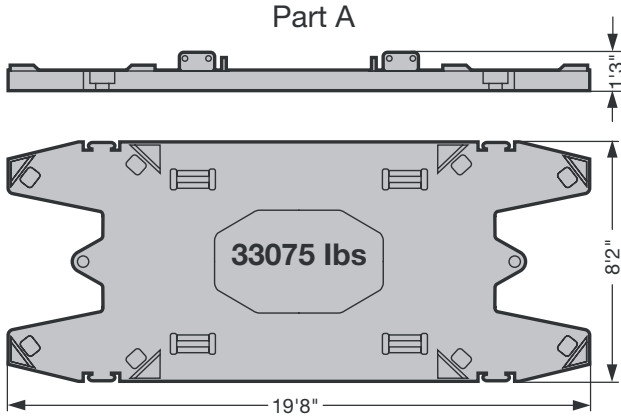
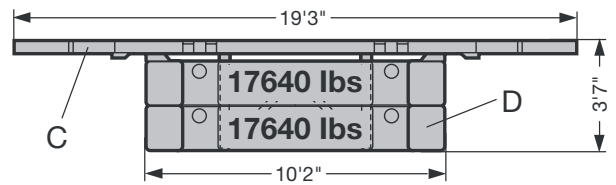

	Part A à 33075 lbs	Part B à 22050 lbs
297 kips	1 x	12 x
341 kips	1 x	14 x

	Part C à 12130 lbs	Part D à 17640 lbs
24 kips	2 x	0 x
95 kips	2 x	4 x

S1531

STERLING CRANE

Transportation plan Plan de transport

Boom intermediate sections Eléments de flèches intermédiaires	B x H	Base length Longueur de base	Transport length Longueur de transport	Weight lbs* Poids lbs*
LA 2620.10	9'2" x 7'10"	23'	24'3"	6400
		45'11"	47'3"	11900
LA 2620.8	9'2" x 7'10"	45'11"	47'3"	9700
NA 2115.10	7'7" x 5'11"	23'	24'3"	3300
		45'11"	47'3"	6200
NI 1812.10	6'7" x 4'11"	23'	24'3"	3000
		45'11"	47'3"	5500
D 2115.20	8'2" x 6'3"	23'	24'3"	5950
S 2620.20	9'2" x 7'10"	23'	24'3"	8160
		45'11"	47'3"	15200
W 2116.20	7'10" x 6'3"	23'	24'3"	3750
		45'11"	47'3"	6600

* Weights incl. guy rods and bolts / Poids avec barres de haubanage et boulons

