



## TRANSPORTATION SPECS - Rough Terrain Cranes

### TADANO MODEL TR-280XL - 28 TON CAPACITY

#### COMPONENT WEIGHTS

	<u>LBS.</u>	<u>KGS.</u>
Complete Crane (1) (incl. block, ball, jib & additional counterweight)	51,314	23 276*

\*Actual scaled weight

#### ADDITIONAL INFORMATION

30 Ton Block	600	272
4.4 Ton Ball	220	100
24' 6" Jib	882	400
Additional Counterweight (required with main hoist only)	882	400
Auxiliary Hoist & Sheave installed on units 28-1-684, 685 & 781 (additional counterweight not required)	1,145	520
Main Load Line (16 mm x 150 m)	354	161
Auxiliary Hoist Line (16 mm x 68 m)	160	73
Tires		

#### TRANSPORTATION

##### Alberta and Saskatchewan

- |                           | <u>Weight</u> | <u>Trailer</u> |
|---------------------------|---------------|----------------|
| • Spring, Summer & Winter | (1)           | Tri-Axle       |

##### British Columbia

- |                           |     |          |
|---------------------------|-----|----------|
| • Spring, Summer & Winter | (1) | Tri-Axle |
|---------------------------|-----|----------|

##### Colorado

- |     |          |
|-----|----------|
| (1) | Tri-Axle |
|-----|----------|

##### Ontario

- |     |          |
|-----|----------|
| (1) | Tri-Axle |
|-----|----------|

# STERLING CRANE

## DIMENSIONS

(20.5 X 25 Tires)

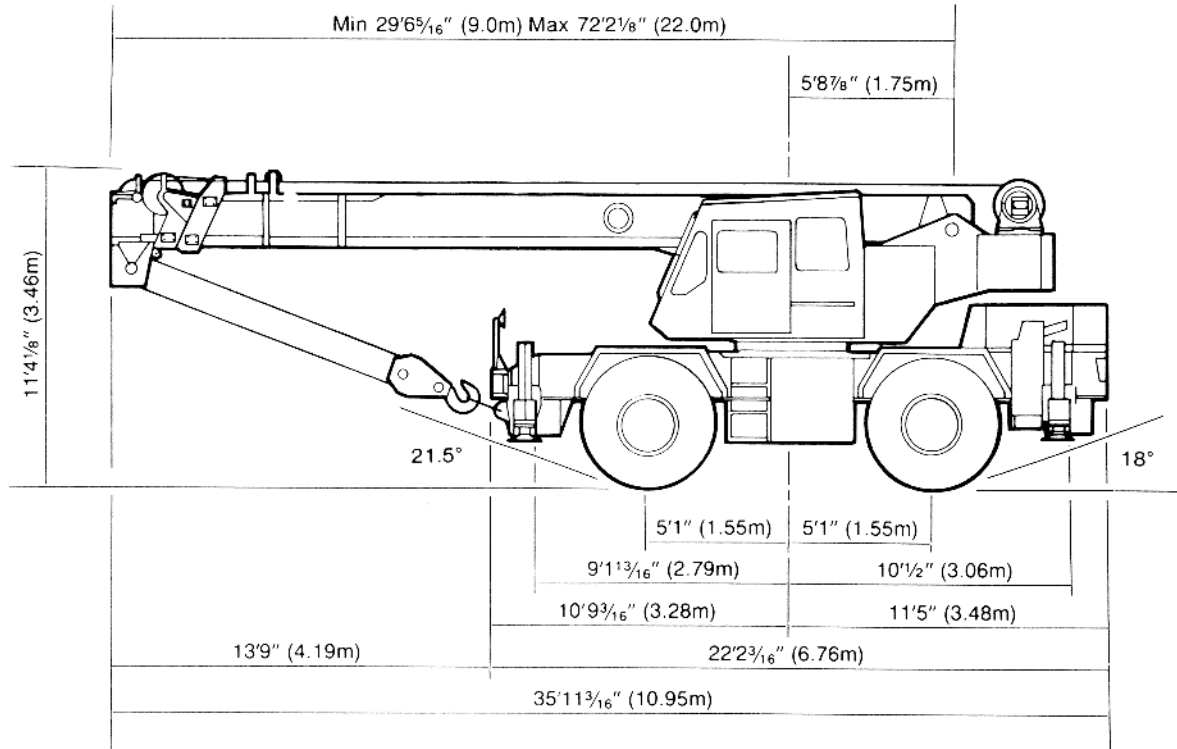

## GENERAL DIMENSIONS (20.5 X 25 Tires)

	Feet	Meters
Tail swing counterweight	9' 8 1/8"	2.95
Turning Radius:		
4 wheel steer	20' 11 3/4"	6.4
2 wheel steer	35' 9 1/8"	10.9

